



# Technical Rescue Core Qualifications

---

## STUDENT MANUAL

GFA revision July 2008



# Table of Contents

Preface  
Acknowledgements  
Schedule  
Terminal Performance Objectives

*\* Note: Some subjects listed below can be cross referenced to the text: "High Angle Rescue Techniques 3<sup>d</sup> Edition" (HART). The associated chapter is also noted.*

---

## Technical Rescue Operations

---

### Chapter 1: Requirements and Safety

General Requirements  
Entrant Requirements  
Minimum Requirements  
Course Safety Rules

---

## Patient Care

---

### Chapter 2: Patient Care & Medical Considerations

*(All subjects indicated with an \* can be referenced to HART, Chapter 12)*

\*Medical Preplanning  
The Decision to Rescue  
\*Causes of Emergencies & the Hazardous Environment  
\*Medical Issues in Technical Rescue  
\*Extended Patient Care  
\*General Rescue/ Medical Principals

### Chapter 3: Litters in Technical Rescue

*(All subjects indicated with an \* can be referenced to HART, Chapter 15)*

\*Rigged Litters  
\*Two Piece Litters  
\*Flexible Litters  
\*Litter Options

### Chapter 4: Patient Packaging

*(All subjects indicated with an \* can be referenced to HART, Chapter 15)*

\*Patient Packaging and Considerations  
\*Movement Considerations  
A Diagram of Patient Packaging

### Chapter 5: Litter Tending

*(All subjects indicated with an \* can be referenced to HART, Chapter 17)*

\*Litter Tending  
Methods of Attachment for the Attendant  
\*Litter Attendant Positioning

---

## Vertical Operations

---

### Chapter 6: Mechanical Advantage

*(All subjects indicated with an \* can be referenced to HART, Chapter 18)*

- Work & Mechanical Advantage
- Levers
- Inclined Planes
- \*Mechanical Advantage & Ropes
- \*Mechanical Advantage & Ropes - Terminology
- \*Types of Mechanical Advantage
- \*Mechanical Advantage System Components
- Mechanical Advantage Problems - Exercise
- \*Pulley Efficiencies
- \*Pulley & Carabiner Comparison

### Chapter 7: Vertical Haul Systems

*(All subjects indicated with an \* can be referenced to HART, Chapter 18)*

- \*Considerations for Rigging Haul Systems
- \*Managing the Edge
- Calling Commands
- Changing over a loaded system

### Chapter 8: Slope Haul Systems

*(All subjects indicated with an \* can be referenced to HART, Chapter 16)*

- \*Terrain Evaluation
- \*Rigging the litter for sloped terrain
- \*Hauling the Litter in Sloped Terrain
- \*Litter bearer attachment methods

### Chapter 9: Portable Height Advantage

- Commercial Devices
- Alternative Uses for Fire Service Ladders
- Other Uses for Fire Service Ladders

---

## Skills Sheets: Check-off Criteria

---

---

## Appendix

---

## Preface

Technical Rescue is often times a high risk operation for a low frequency of occurrence. Often times hours and hours are spent learning technical skills; however, without regular practice, skill degradation will occur. Ideally, regular practice drills, scenarios and hands-on training within the department would be available for all levels of training and departmental procedures would be in place to retain skills. However, in reality it is often times up the individual to strive above and beyond the norm to retain skills that are of most interest.

Since Job Performance Requirements are written to encompass minimum requirements, the ideal goal of mastery of difficult to achieve without focusing on a particular specialty. Below are a few considerations that may help each rescuer as they strive to become a technician:

- Cautions- Technical Rescue is inherently dangerous. Safety is paramount.
- Time- Technical Rescue requires many hours of hands-on practice and training.
- Strive to understand multiple applications of skills and “why” specific techniques are used.
- Keep skills sharp- If you don’t use it, you’ll lose it!
- Continual education- Skills used in rescue may transfer to, or be transferred from other interests. Rock climbing skills are often used in Tower Rescue. Arborist workers use some of the same concepts found in vertical climbing techniques. Specific techniques may be very different, but the basic concepts can be transferred to many others technical skills.
- Learn from different sources.
- Practice individually, and as a team.

## Acknowledgements

Without the following, none of the GFA programs would be available:

- All the people that have worked to develop this program.
- Testers and professionals dedicated to the betterment of gear and techniques.
- The instructors that teach and mentor others.
- The rescuers that make it happen.



## Technical Rescue Core Qualifications: 48 hrs

	Day 1	Day 2	Day 3	Day 4	Day 5	Day 6
08:00	Registration, Course Overview, Introductions  Intro Course Review	Morning Review & Skills Practice	Morning Review & Skills Practice	Morning Review & Skills Practice	Morning Review & Skills Practice	Written Exam
08:30						
09:00						
09:30	Medical Considerations in Technical Rescue	Mech. Advantage: Overview	Litter Tending: Overview	Changeover Loaded Sys.	Student Run Scenarios  Small Groups	Skills Check-offs
10:00				Slope Ops with Portable Anchors & Vertical Ops using Portable Anchors		
10:30	Mech. Advantage: Practice Stations	Litter Tending: Practice				
11:00			Patient Packaging: Overview & Practice			
11:30						
12:00	Lunch	Lunch	Lunch	Lunch	Lunch	Lunch
12:30						
13:00	Patient Packaging: Practice  Lowering Operations with Litters	Hauling Operations without Litters  Hauling Operations with Litters	Vertical Ops with Litter Tender  &  Portable Anchors: Overview & Practice	Slope Ops with Portable Anchors  &  Vertical Ops using Portable Anchors	Student Run Scenario  Large Group	Skills Check-offs
13:30						
14:00						
14:30						
15:00						
15:30						
16:00						
16:30						
17:00- Finish	Questions clean up	Questions clean up	Questions clean up	Questions clean up	Questions clean up	Demob & Evaluations

Classroom

Bay/ Trees

Tower/ Cliff or Slope

## Terminal Performance Objectives

1. Given classroom instruction, demonstration, technical rescue scenarios, and limited medical equipment, the student will be able to assess the need for patient packaging and recommend needed patient treatment(s) appropriate for the patient and environmental circumstances with 100% accuracy according to skills check-off criteria.
2. Given classroom instruction, the student will be able to identify a variety of patient packaging devices likely to be utilized in a technical rescue operation with 100% accuracy according to skills check-off criteria
3. Given classroom instruction, demonstration, a rigid litter, auxiliary litter packaging equipment and technical rescue scenarios, the student will be able to package a patient in preparation for movement in a low and high angle setting likely to be utilized in a technical rescue operation with 100% accuracy according to skills check-off criteria
4. Given classroom instruction, demonstration, and general equipment likely to be used in a technical rescue incident, the student will be able to build and operate 3 types of simple mechanical advantage systems likely to be used in a technical rescue with 100% accuracy according to skills check-off criteria
5. Given classroom instruction, demonstration, rescue scenarios, and general equipment likely to be used in a technical rescue incident, the student will be able build and operate a vertical haul system likely to be used in a technical rescue with 100% accuracy according to skills check-off criteria
6. Given classroom instruction and general equipment likely to be used in a technical rescue incident, the student will be able to evacuate a patient from sloped terrain without further injuring the patient or rescuers, with 100% accuracy according to skills check-off criteria
7. Given classroom instruction, demonstration, a tripod and rescue equipment, the student will be able build and use at least two types of portable height advantage likely to be used in a technical rescue with 100% accuracy according to skills check-off criteria.
8. Given classroom instruction and rescue equipment, the student will be able to tend a litter in a vertical technical rescue operation, with 100% accuracy according to skills check-off criteria.
9. Given classroom instruction, demonstration, a loaded raising and/ or lowering system, and auxiliary rescue equipment, the student shall safely demonstrate changing the systems components to affect the direction of travel of the load with 100% accuracy according to skills check-off criteria

---

# Technical Rescue Operations

---



# Chapter 1: Requirements and Safety

---

The Georgia Fire Academy (GFA) has reviewed the current standards related to technical rescue programs according to the National Fire Protection Association. In reviewing those standards, each student should meet certain requirements prior to training, and perform skills during training, to practice as an active technical rescuer.

## General Requirements

Rescue Technicians shall complete all activities in the safest possible manner and shall follow national, federal, state, provincial, and local safety standard as they apply to the rescue technician.

## Entrant Requirements

- 1) Age requirements- Each student shall be at least 18 years of age.
- 2) Medical requirements- First Responder or Equivalent, inclusive of current First Aid & CPR.
- 3) Minimum physical fitness- Each student shall be in good to excellent physical fitness. Student with special needs or physical concerns should alert the instructor so the best treatment can be provided should an issue arise; i.e. allergies to bee stings, diabetes, etc.
- 4) Prerequisite knowledge- Introduction to Technical Rescue or Intro to TR Skills Challenge
- 5) Members of specialized teams will be given priority in advanced technical training over firefighters that are not active as a member of a responding technical rescue team.

## Minimum Requirements

For certification, as a Rescue Technician, the student shall perform all of the job performance requirements in NFPA 1006 Chapter 5 (Core Skills) and all job performance requirements listed in the NFPA 1006 Chapter specific to their choice of discipline (Discipline Skills.) These requirements are the skills needed for minimum job performance as the rescue technician. Should a student be unable to complete all of the specified skills, then the student is not eligible to become certified as a Rescue Technician, according to NFPA standards.

This course continues to build upon the skills practiced in the GFA- Introduction to Technical Rescue course. This course will introduce more minimum job performance requirements and continue to build the necessary skills to perform technical rescue operations for fire service and other emergency response personnel. Technical Rescue Core Qualifications will train individuals the knowledge, skills, and duties needed to perform as part of a technical rescue team member, using the general requirements established by National Fire Protection Agency (NFPA) 1006, Professional Qualifications. Performance testing will evaluate general skills such as victim movement, patient packaging, and basic techniques to utilize ropes systems used in sloped and high angle settings.

**Attendance Policy-** Students must attend and participate in 90% of the course in order to receive GFA credit. No more than 4 hrs of an excused absence are allowed during the course for completion.

**Written Test Policy-** Students must attain a minimum score of 70% on a written exam delivered by the Georgia Fire Academy.

**Performance Test Policy-** Students must perform, complete and pass every skill as part of there performance testing administered by Georgia Fire Academy. Records of performance testing will be held in office of Georgia Firefighters Standards and Training Council as well as in GFA records.

## Course Safety Rules

Safety is of the utmost importance at all times. Technical Rescue is inherently dangerous. Safety in a technical operation should be a primary focus during all training and operations. Follow these safety considerations when participating in this program.

### General Safety:

- Be safe in all your actions- act responsibly.
- Use proper lifting techniques when handling heavy rescue equipment.
- Horseplay will not be tolerated.

### Instructor and student roles:

- The instructor is in charge and responsible for overall safety.
- The student is responsible for personal and team member safety.
- All elements of a load supporting operation must be inspected by an instructor prior to use.

### PPE:

- Approved helmet must be worn by everyone within 10 meters (30') of vertical rope work, or when falling objects are likely.
- Approved class III harness must be worn during rappelling, lowering and raising operations.
- Gloves should be worn when handling a rope in movement.
- Safety glasses, goggles, ear protection or other special PPE may be needed during operations.
- Have an instructor or two other students inspect proper harness donning before beginning vertical exercises.

### Equipment:

- Rescue equipment will be inspected before, during and after daily use.
- Equipment will be inventoried before and after class.
- Damaged or suspect equipment will be given to the rescue course coordinator, or Logistics Instructor, for preliminary inspection. The course coordinator may temporarily retire equipment for the class until a more detailed inspection is possible.
- Abused hardware or hardware dropped from an extreme height resulting in obvious damage, must be taken out of service immediately Tagged, Marked or Destroyed and delivered to the course coordinator, or Logistics Instructor, upon conclusion of the training.
- No type of tobacco use within 15 meters (50ft) of any nylon, polyester or other soft goods.
- No knives around loaded ropes.
- Avoid stepping on, or dragging, ropes and other software.
- Secure loose items which may become entangled in descent devices or other snagging obstacles.

### Environment:

- Establish safety zones when potential hazards are present.
- Establish safety lines, and remain secure during operations.
- Everyone must be secured to an anchor a body lengths distance from an edge, unless protected by a handrail or parapet wall.
- Secure equipment when it may be knocked or kicked over an edge.
- Secure equipment to avoid loss or damage.
- Point out any potential hazards to an instructor and other students.

### Communications:

- Follow the chain of command.
- Use "*GATE-CHECK*" and touch method when inspecting carabiner components of systems.
- Use "*STOP, STOP, STOP*" command to cease all operations IMMEDIATELY.
- Use the universal warning call: "*ROCK!*" whenever you notice any falling object.
- Ask questions if you have any rescue or safety-related concerns.



---

## Patient Care

---



## Chapter 2: Patient Care and Medical Considerations

---

### Terminal Performance Objective:

Given classroom instruction, demonstration, technical rescue scenarios, and limited medical equipment, the student will be able to assess the need for patient packaging and recommend needed patient treatment(s) appropriate for the patient and environmental circumstances with 100% accuracy according to skills check-off criteria.

### Enabling Objectives:

- Assess a victim so that injuries are identified, treatment priorities are established while minimizing risks to the rescuers.
- Stabilize and provide basic life support to the victim suitable for the given environmental conditions.
- Triage victims if/when multiple victims exist to prioritize resources and victim management.
- Identify special medical techniques that may be used when long term incidents are anticipated.
- Discuss special medical problems that may arise for the victim in technical rescue operations.

### Medical pre-planning

Preparing for the care of a victim during a technical rescue must begin prior to the occurrence of the incident. Scenario based training can guide a team in the development of medical protocols and identify team needs. Teams must identify equipment needs vs. applicability to specialized incidents. Consideration toward team member medical skill levels plays an integral part in recognizing team capability. Strong medical control, on the part of a sponsoring physician, is paramount. This will help to substantiate and enact the team's medical protocols.

### The Decision to Rescue

Hazard assessment will dictate the team's tactical objectives. Teams must ensure there are no additional collapse hazards prior to entry into areas such as a trench or structural collapse. These areas must first be shored and secured. Utilization of lockout/ tagout procedures must be taken to secure any hazardous form of energy. This includes electrical, pneumatic, hydraulic and pressurized sources. Teams must assess fall potential and protect rescuers from this hazard by providing for fall protection. Atmospheric conditions must be at acceptable levels or controlled through ventilation of the space or respiratory protection. Protection from environmental conditions including hot, cold, humid or dry environments must be considered due to their effects on long-term exposure. Engulfment hazards may include loose materials or liquids which can entrap a rescuer. Retrieval lines or flotation devices should be considered as a means of protection for these engulfment hazards.

Team members must be highly trained and competent. Certification in a particular technical skill does not merit competency. Skills must be practiced and mastered in a multitude of environments. Experience may be gained through realistic, scenario based exercises that challenge the rescuers skills. Physical stamina is imperative for members of a highly proficient technical rescue team.

The team must assess its medical equipment for \_\_\_\_\_, \_\_\_\_\_ and \_\_\_\_\_ in a technical environment.

Conditions surrounding most technical rescue incidents are not conducive to the fragile nature of most “street” EMS equipment. A hasty medical kit should be assembled in a durable, waterproof case. The contents of this kit should provide for BLS level care to give the first arriving rescuers the ability to provide care for injuries that are considered life threatening. Resist the urge to cram the medical kit full of un-needed medical supplies. Try to stock materials that have multiple uses. One example is the use of 4X4 gauze. Place a couple of large bandages or abdominal dressings that can be cut into smaller pieces instead of packing the medical kit full of 4X4's.

Determine: rescue or recovery? This will dictate the tactical objectives for the team. Team members should be informed of the intent to perform rescue or the realization that no amount of training or equipment will overcome the inevitable. Recovery operations will need to move at a cautious pace vs. rescue operations where tactical operations may need to employ less than desirable (by the book) techniques in order to save the patients life.

Once a decision has been made to attempt the rescue...

Safety of the rescuers should be top priority. Hazard isolation and mitigation is necessary in order for the team to enter into the hazard zone to begin medical care. Patient stabilization, when possible, will buy more time for the team to setup for the most effective method of extraction. The patient's condition, whether stable or deteriorating, will drive extraction methods. Unstable patients will need to be extracted quickly, using simple methods and techniques such as the application of a hasty harness vs. packaging a patient in a litter. Stable patients will allow the team more time to establish more efficient extraction methods that utilize the team's equipment and skill to perform the extraction.

### Causes of emergencies

\_\_\_\_\_ account for the majority of technical incidents.

Whether the environment was unforeseen (bomb blows up building), not perceived as a threat (cave with bad air) or was predictable (un-shored trench), the environment is likely to have caused the victims medical complications. The result is either traumatic or medical issues due to the impact of the hazardous environment.

### Dealing with a hazardous environment

Focus on the isolation of the hazard(s). For patients who are not breathing consider the possibility of immediate extraction. It does no good to “set up shop” inside a hazardous environment. Alternative extraction

methods must be considered. These include rapid extraction methods such as hasty harnesses, handcuff hitches, drags and carries. Spinal precaution and resuscitation efforts should take place outside the space and do not take precedence over removal from an IDLH environment that is uncontrollable.

## Trauma Victims

Airway and C-spine control is important and should be applied to patients who are stable and in a suitable environment. Focus on the ABC's of patient care and seek out additional injuries that may become life threatening. Don't overlook medical issues. The patient may have sustained traumatic injuries due to a medical problem. Look for traumatic injuries that may be secondary to the medical condition. The inverse is also an important consideration.

Most rescuers focus on the trauma and fail to recognize \_\_\_\_\_ - \_\_\_\_\_ conditions.

## Medical Emergencies

Common medical emergencies include heat/ cold exposure, neurological emergencies, cardiac emergencies and fatigue. There is a limited amount of care that can be given for most medical emergencies in the technical rescue environment. However, some medical conditions can, and should, be treated onsite. One common medical condition is hypoglycemia. This can easily be detected and treated at the BLS level. Some medical emergencies may be treatable on site which will allow for a less technical extraction.

## Suspension Trauma (Harness suspension pathology)

This potentially fatal condition occurs when a person hangs, motionless, in a seat harness for a long period of time. The reduction in venous return, due to constriction, results in poor cardiac output, deoxygenated blood and an increase in acid levels within the blood stream. It can occur within minutes and is dictated by the individual's mental state, build, physical condition and medical history. Outside influences that will also affect an individual's response include cold or wet climates as well as high temperature and humid environments. Both, which affect fluid loss or vasoconstriction. Victims must be lowered quickly and removed from the harness. Care should be taken to handle these patients gently due to the possibility of the condition progressing to Crush Syndrome.

If the victim is conscious, have them try to move their extremities to facilitate blood flow. Not much movement is required. You can direct the patient to simply flex their toes or shuffle their feet. Another simple and effective technique is to lower a rope with a loop that the patient can use to stand up in to relieve pressure from their harness. This will buy the team some time to complete the rigging of their rescue system.

## Crush Syndrome (Compartment syndrome)

Like suspension trauma, crush syndrome results from restriction of blood flow from the affected body part and results in increased acid levels within the blood stream. This condition is usually the result of entrapment of the victim. The affected body part is under constant pressure, resulting in the tourniquet effect. Care should be taken to handle these patients gently in an effort to minimize the rapid return of deoxygenated and acidic blood back into the cardiac system. The unfavorable effects of Crush syndrome include renal failure, cardiac dysrhythmias or vasodilatation (low blood pressure). Patient care should be under the direction of an on site physician.

## Extended patient care

Prolonged extraction times will require consideration in the long term management of the patient's injuries. The Golden hour is generally the benchmark of every rescuer for a victim to reach a definitive care facility. However, due to the complexity of technical incidents, it may be impossible to achieve this goal. Certain situations dictate the use of ALS care in the field and may even require that physicians be onsite to treat the victim throughout the extraction process. These situations include heavy machinery extrication, trench rescue, building collapse and cave rescue. These types of incident commonly require extensive extraction methods and may include very difficult terrain. Some important things to be considered for extended care situations include:

- \_\_\_\_\_ – the use of therapeutic drugs must be within the agencies medical protocols and administered by an individual with the appropriate level of medical license.
- \_\_\_\_\_ – Many patients will be in extreme pain due to their predicament. Pain management medications may be appropriate for the management of these patients. Again, follow protocols, seek medical direction where necessary and monitor the patient's condition and vital signs throughout the extraction.
- \_\_\_\_\_ – This is an often overlooked patient need. Most technical rescue extractions will be lengthy. The injuries sustained by the patient will require their body to go into "overdrive" to begin the healing process. Nutritional needs are increased. The team needs to take this into consideration and try to meet those needs, where appropriate. Patients experiencing hypothermia will also need food to increase metabolism, thereby increasing body temperature.
- \_\_\_\_\_ – What goes in, must come out. The team should make appropriations for this. It may be necessary to catheterize the patient or place them in an adult diaper.
- \_\_\_\_\_ – The patient must be monitored for the signs and symptoms of shock. This will become difficult with patients placed inside bulky blankets and vapor barriers which limit the use of BP cuffs and stethoscopes. One trick is to place medical monitoring equipment on the patient prior to completing packaging. This includes IV ports for drugs or fluid boluses or placing the BP cuff and stethoscope on the patients arm. Leave the Sphygmomanometer and stethoscope earpiece where it can be easily accessed. Oxygen therapy may be limited due to terrain or extraction time.
- \_\_\_\_\_ – Body temperature regulation is another important aspect of patient care. The team must provide a means to regulate, and monitor, the victim's core temperature throughout the extraction. Even mild temperatures can cause the victims body temperature to plummet. The use of body core temperature sensors, with a remote display is very effective for prolonged extractions or in harsh environments.

## General Rescue/ Medical Principals

- Protect the patient from further injury
- Not all injuries require treatment before rescue
- Advanced care will likely conflict with technical rescue extraction methods and are difficult to perform in this environment
- Good BLS is safer and more effective than poor ALS
- Alternative methods of extraction should be considered for deteriorating patients
- Rescuers should anticipate and prepare for patient care problems that may arise during extraction

## Point to ponder

“It does no good to perform an impressive rescue and kill the patient.”

Do not fail to recognize the importance of good BLS care coupled with the utilization of basic rescuer skills to effect a successful patient extraction. All the training and equipment in the world will not overcome poor decision making.



## Chapter 3: Litters in Technical Rescue

### Terminal Performance Objective:

Given classroom instruction, the student will be able to identify a variety of patient packaging devices likely to be utilized in a technical rescue operation with 100% accuracy according to skills check-off criteria.

### Enabling Objectives:

- Identify a minimum of 3 types of rigid litters.
- Identify a minimum of 2 types of flexible litters.
- Identify at least 3 advantages and disadvantages of a rigid litter as compared to a flexible litter.
- Identify general testing and strengths requirements of a MilSpec litter.

Patient movement in a technical rescue often times requires the use of a litter in either a low angle or high angle setting. There are several types of immobilization techniques and transportation devices that may be utilized to transfer a victim to an ambulance or helicopter. Below are few of the common types of devices used in technical rescue. There are many other types of immobilization devices available, so it is important to practice with the types of devices that your agency uses.

What ever the brand, type or style, a litter used in rescue should provide theses basic functions for the injured victim:

\_\_\_\_\_ + \_\_\_\_\_ + \_\_\_\_\_

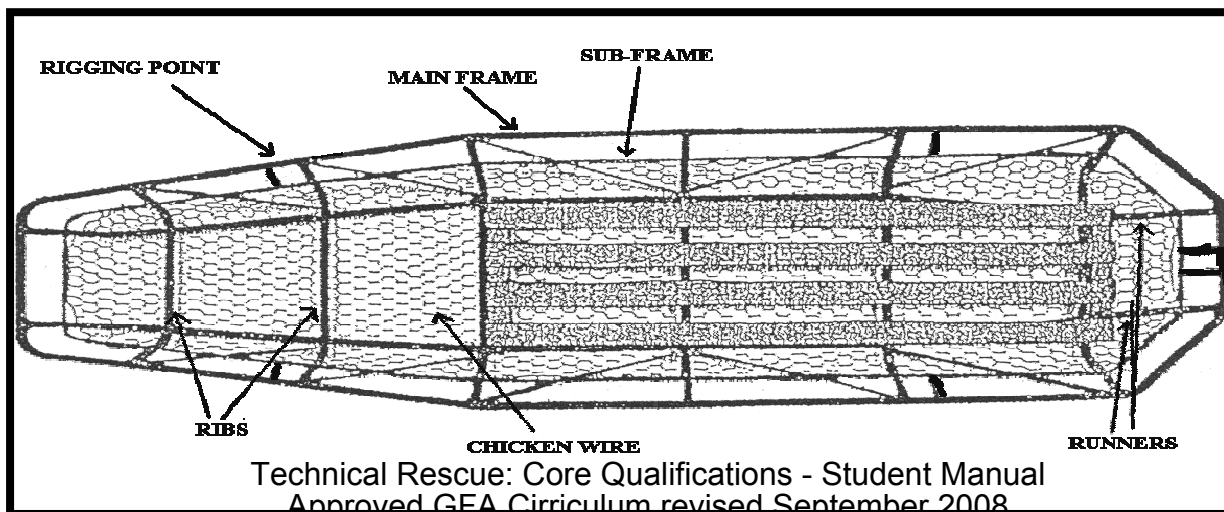

## Rigid Litters

### Metal Basket Litters:

- Often called a “Stokes” basket litter reminiscent of an early design by Charles Stokes.
- The word “basket” suggests a litter that the patient is placed “into” to protect the patient from falling out, rather than on top of such as a backboard.
- Usually constructed with a wire, metal or stainless frame, and covered with a metal, plastic or chicken wire mesh.
- Newer models may be constructed of a titanium tubing which are extremely light weight but more expensive than the traditional metal basket litter.
- Basket Litter may be rectangular or tapered at one end
- Some backboards may not fit into tapered basket litters.
- Some models have leg dividers, which can not accommodate a backboard.
- Traditional shapes may be difficult or impossible to maneuver in confined space environments.
- Care should be taken when using mesh basket litters to protect the patient from objects that may poke or impale through the mesh from the bottom of the litter.
- Blankets may be used to provide added protection, and warmth as needed.
- Verify connections points as different manufacturer recommend only specific areas to be used when lifting the litter vertically or horizontally.
- MilSpec refers to a design load more than a testing criterion. 2500# must be raised and held in place. NFPA does not.
- Most popular brands include: Traverse, Cascade Toboggan, Ferno and Junkin Safety Appliance Co.



Cascade  
Toboggan  
Litter



Traverse Litter

## Plastic Basket Litters:

- Either all plastic except for a metal top rail, or may have a metal steel frame (much like a metal basket litter) with a plastic shell.
- Plastic Litters are usually not as strong as a metal basket litter.
- Plastic litters should not be exposed to UV for long periods of time- the UV will degrade the high density polyethylene and cause it to become brittle. Even though newer models have addressed this issue in material choices, older models are 'particularly susceptible to this type of deteriorations, and the plastic may fracture when stresses under extremely cold conditions.'
- Usually weighs less than a metal basket litter.
- Solid bottom allows it to slide easily over terrain such as rock and snow.
- Provide more protection for the patient on rough terrain.
- Should never be used in short haul operations- the solid bottom will create high spin rotation cause by helicopter rotor wash.
- Most popular brands include: Ferno Washington 71 and Junkin JSA-200.



Ferno Litter

## Two Piece or Break-Apart Litters

- A metal or plastic basket litter that is designed to be split into two sections.
- Popular among wilderness and mountain rescue groups for easy transport to the patient.
- Also uses less space to store or pack into a vehicle.
- May rejoin using a pin or threaded connection.

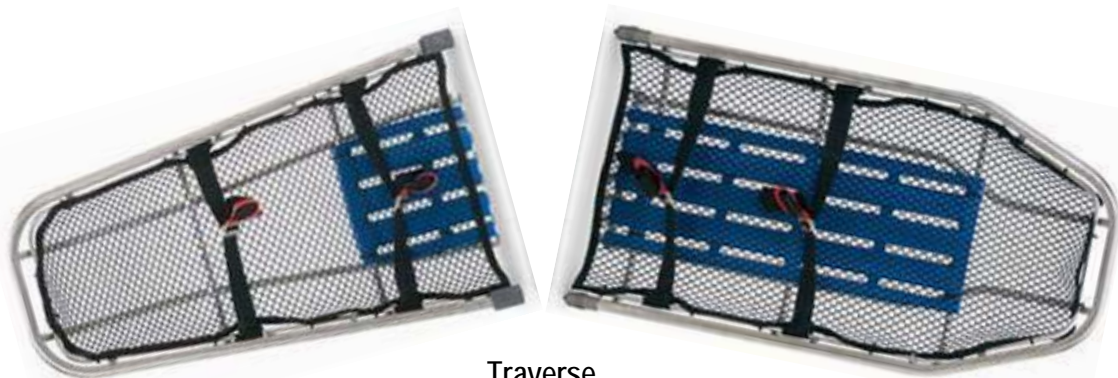

Traverse  
Break-Apart Litter

## Flexible Litters

- Unlike basket litter, a flexible litter does not have the rigid frame or structure.
- Instead, a flexible litter wraps around the patient like a cocoon.
- Easy to work with in confined spaces.
- Can also be used as a tough drag sheet in mass casualty situations or for decontamination in hazmat environments.
- Very lightweight
- Can be stored or carried in a compact backpack.
- Adaptable for a reasonable cost.
- Can not be used with most litter wheels.
- Not rigid enough to be carried by two people at either end.
- Spinal immobilization must be used to provide rigidity or when planning to vertically lift a patient. A short board, such as an OSS or KED can be used.
- Most popular brand is a Sked Litter.



Sked Flexible Litter

## Litter Options

- A litter shield covers the patient from falling debris and other environmental hazards.
- A litter wheel makes transportation over horizontal and sloped terrain easy and requires fewer rescuers than manually carrying the litter.
- Floatation collars or side devices can be attached to some litters to provide some flotation in watery environments.



Litter Shield



Litter Wheel



# Chapter 4: Patient Packaging

---

## Terminal Performance Objective:

Given classroom instruction, demonstration, a rigid litter, auxiliary litter packaging equipment and technical rescue scenarios, the student will be able to package a patient in preparation for movement in a low and high angle setting likely to be utilized in a technical rescue operation with 100% accuracy according to skills check-off criteria.

## Enabling Objectives:

- Package an ill or injured victim appropriate for the environmental conditions while minimizing potential further injury.
- Demonstrate a minimum of three (3) different techniques to move a litter without further injury to the patient or the rescuers.
- Move a victim in a low-angle or high angle setting until rescuers and victim are removed from the environmental hazard.
- Transfer a victim to EMS for continued or advance medical care, and discuss the ethics associated with patient confidentiality.

When an injured person is unable to evacuate under his/her own power, or with some assistance, packaging the patient in a litter of some sort may be needed. Some concerns that should be considered include:

- Protecting the subject from physical and environmental hazards.
- Provide for the subject's comfort.
- Physically stabilize the subject to prevent harmful movement.
- Protect medical equipment, such as IV's or access site for IV's and bandages.

## Patient Packaging

### Blanket Wrapping:

- Helps prevent shock
- Pads wire mesh to enhance comfort
- Helps protect patient from falling debris & undercarriage intrusions
- Adds a sense of security (gives the patient a warm and fuzzy feeling all over)

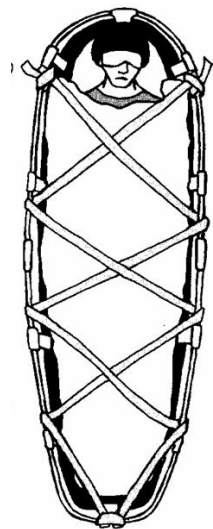

### "Patient Protection"

- Vapor barrier is placed first. Protects patient from wet or contaminated environments. (off set to one side)
- Blankets/ thermal protection is placed next ("T" method)
- Fold over top corners to allow space for victims head to be visible.
- Fold over short side of barrier/blanket first and overlay the long side & tuck it in to limit debris and water entrapment.

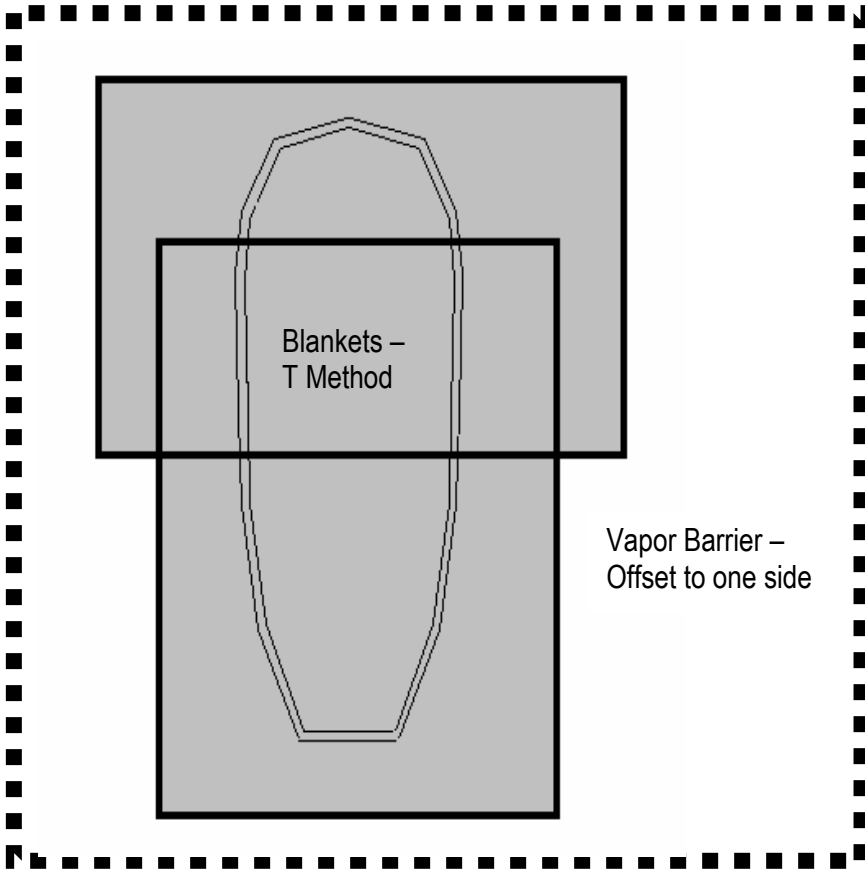

### Packaging Considerations:

- Pad the voids, i.e. between ankles under knees, small of back.
- Cervical immobilization should be performed, where appropriate, when spinal injury is suspected.
- Head protection is needed for movement through the technical environment. When spinal immobilization is needed, consider a patient shield since a helmet may further injury.
- Eye protection such as goggles or safety glasses should also be used to protect the patient's eyes from the inevitable debris that will fall during extraction.
- For unconscious patients, keep arms secured inside litter, especially down to the elbows. Conscious and cooperative patients may resist having their arms lashed down. Take into consideration the patient's level of cooperation when determining how you will secure their upper extremities. Remind patients to keep their arms inside the litter and avoid grabbing anything during movement.
- Patient placement in the litter should be centered and slightly toward the head of the basket. Keep at least a hand width between the top of the victim's head/ helmet and the main frame rail.
- Lashing can be done with 1" tubular or flat webbing.
- Lashing should be tight and conform to the patient without restricting airway, circulation or creating potential for further injury.
- Subject should be physically stable so that he/she does not fall out regardless of the angle or direction of litter movement.
- Packaging should be compartmentalized such that access to torso or legs is possible without untying the entire package.
- Place medical monitoring equipment where it can easily be accessed.

## Movement Considerations

- Try to keep litter movement smooth whether on the ground or in the air, avoid bouncing and jolting.
- Head of the patient should remain above the feet, unless shock or special considerations are needed.
- Remember – the patient has a name, use it. Write it on a piece of tape and place it near the head so it's easily seen by other rescuers. This is a small courtesy that will go a long way in lowering the patient's anxiety.

## A Diagram of Patient Packaging:

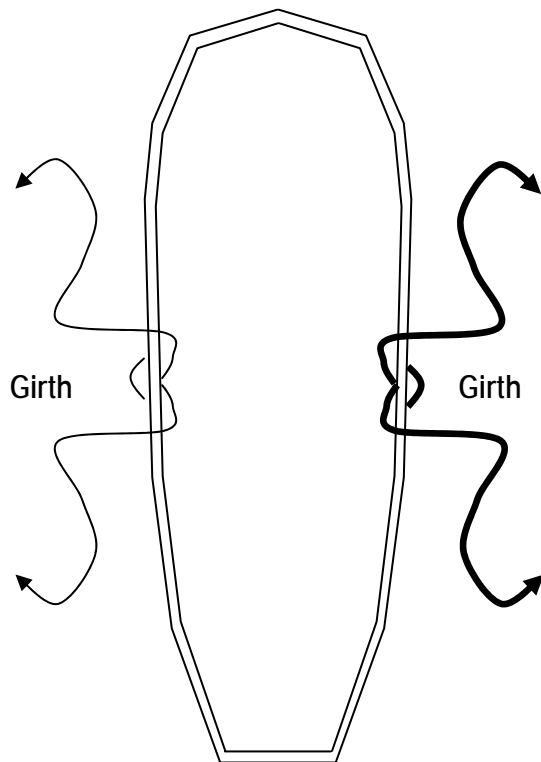

Fig. 1

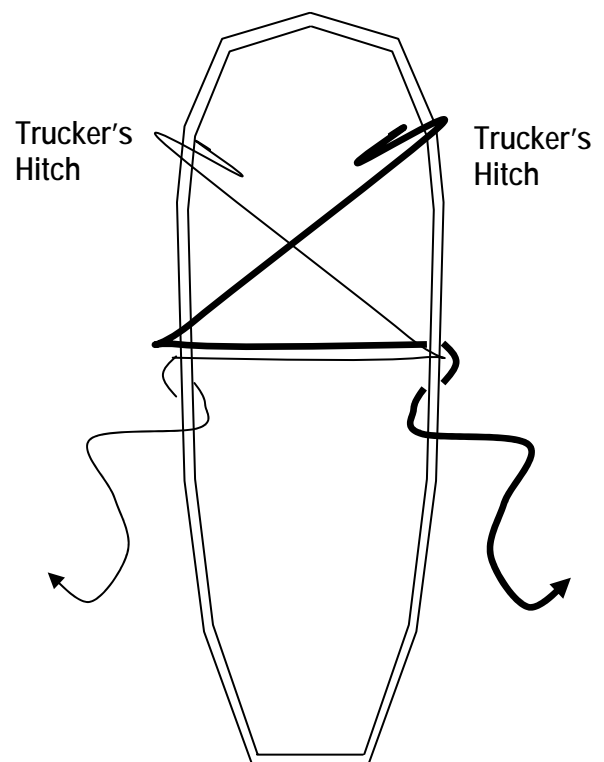
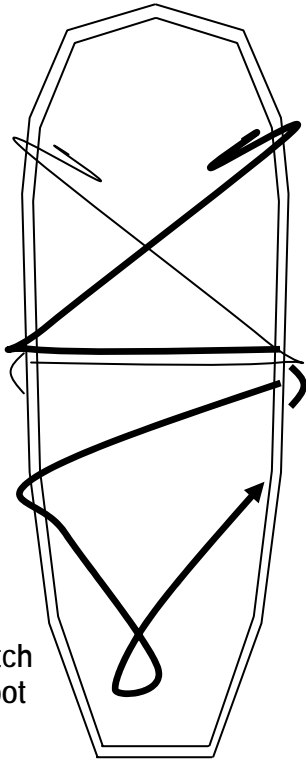

Fig. 2

- Begin with 2- 25' or 30' lengths of webbing
- Girth webbing on a rib or sub frame approximately at the center of the litter or at the patients waist
- Using the upper halves of webbing, cross at the waist and then cross the chest/ upper body
- Avoiding the collar bone, use a truckers hitch to cinch and terminate the lashing





Half Hitch  
each foot

Fig. 3

- Using the lower halves of the 25' webbing, cross the thighs of the patient,
- then loop the closest foot from the interior, under the foot and outside,
- across the shin of the opposite leg,

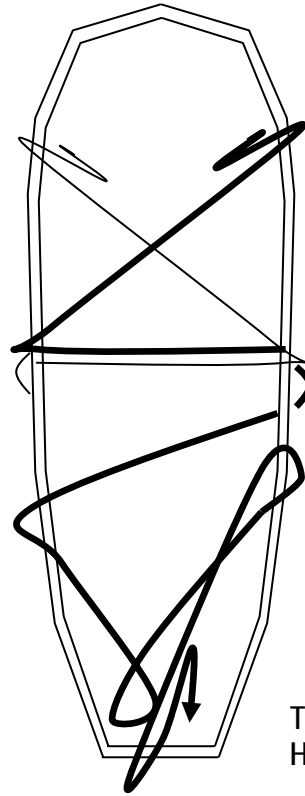

Trucker's  
Hitch

Fig. 4

- back toward the foot of the basket
- use a truckers hitch to cinch and terminate the lashing.



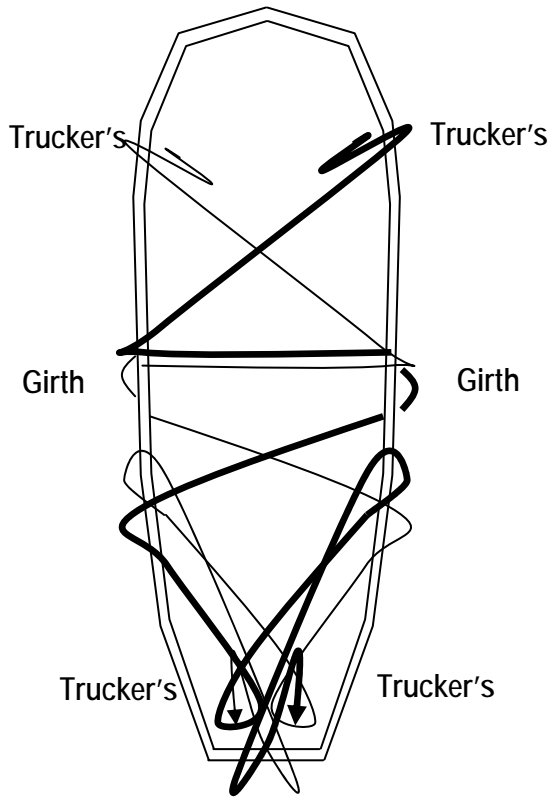

Fig. 5

- Repeat on the opposite side.



## Horizontal Spider attachment

- With Webbing:
  - Tie a frost knot with two legs with a 12 and 15 ft piece of webbing.
  - Each long bight is attached to the litter via carabiners. May use a direct tie method to limit carabiner use.
  - 12 ft spider is attached to the upper portion of the litter.
  - 15 ft spider is attached to the lower portion of the litter.
  - May need to use triangular screw links to prevent cross loading of the attachment to the mainline.
  - One screw link for attachment to belay and another for attachment to the mainline. Screw link on each line will pass through BOTH bights at the frost knot.
- Rope: Pre- tied rope spider. No dead legs. Adjustable.
  - Each spider consists of rope and accessory cord. Usually made of 10mm rope and 6 mm cord.
  - Designed to prevent dead legs when adjusted.
  - Rig one spider at the upper portion of the litter and the other to the lower portion.
  - Make attachments with carabiners.
  - Can be rigged to “clamshell” for quicker removal of patient from the litter. Rig one spider to one side of the litter and the other spider to the opposite side of the litter.
  - One carabiner is used for attachment to belay and another for attachment to the mainline. Carabiner on each line will pass through BOTH bights on the rope spiders.

## Vertical Bridle attachment using rope

- Rope should be  $\approx$  25 – 30 ft long
- Fig 8 on bight or Butterfly tied in center of rope – small hole
- Keep knot CLOSE to mainframe
- Wrap each leg around a minimum of three structural components of the litter. (One leg on the left side, the other on the right side of the litter mainframe)
- Structural components = Mainframe, Runners, Ribs
- Secure each leg to mainframe with clove hitch and a half hitch – above patient’s navel, close to nipple line.
- Pull the legs of rope back to the head of the litter and tie a Fig 8 on the end of each leg to match the position of the first knot.
- Knot on the mainframe is the high attachment point. Knots on the two legs are your low attachment points.
- Mainline and Belay line attachments will depend on the type of edge transition.

## Belay line attachment

- The belay line will be terminated at the spider or bridle attachment.
- A long tail will ONLY be required when there is a litter tender and will be terminated at the tenders harness.
- No harness is required for the patient. The litter is considered as the patients harness.

## Tagline attachments

- Using one end of rope. Tie a Double Loop Fig 8 with long loops.
  - Each loop is attached to the mainframe with carabiners.
  - The wider the bights are the more stable the tagline. This will prevent rolling or flipping.
- Using two ropes. Provides better control. Use direct attachment method – Bowline or Clove hitch

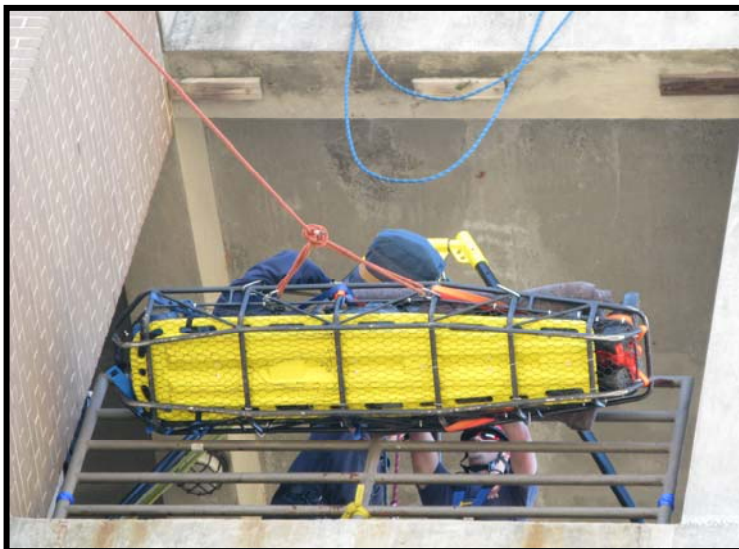



## Chapter 5: Litter Tending

---

### Terminal Performance Objective:

Given classroom instruction and rescue equipment, the student will be able to tend a litter in a vertical technical rescue operation, with 100% accuracy according to skills check-off criteria.

### Enabling Objectives:

- Demonstrate tending a litter rigged in a vertical orientation during a vertical operation.
- Demonstrate tending a litter rigged in a horizontal orientation during a vertical operation.

### Litter Tending

Some rescue extractions require that a rescuer (attendant) remain with the patient at all times to monitor their health, provide reassurance, shield them from environmental hazards and communicate the patient's needs to the rescue team. The attendant may also be required to remain with the victim during vertical operations. The ability to provide medical care while suspended on a rope system is limited, at best, to general BLS monitoring and airway maintenance. The attendant will have to provide for their own protection while being moved through the vertical environment. All while providing a smooth ride for the patient, maintaining litter orientation, communicating to the rescue team and preventing the litter from striking obstructions. Taglines should be employed as the team's first measure of avoiding obstacles. Litter tending should be used as a last resort when taglines or fixed line rope skills are not feasible or possible. Litter tending is a tough job for the attendant and the rescue team performing the Haul/ Lower operations. It is equipment intensive and requires proficiency in edge transition and attendant positioning skills.

### Methods of Attachment

The method of attachment for a litter tender will employ the mini-haul as their main attachment and a long tail from the belay line as the attendants belay. The mini-haul should be attached to the mainline with a prusik or mechanical rope grab. Attachment should be approximately 18 inches above the terminal knot, at the litter attachment point. The position of the mini-haul on the mainline can be varied prior to load suspension. Depending on height help availability, the mini-haul may need to be as low as possible on the mainline. The rescuers belay is attached to the rescuer via a long tail from the belay line. An inline knot is connected to the litter harness with approx. 4- 6 feet of tail "tied in short" with a prusik at the rescuers harness. The prusik will need to be adjusted on the belay as the rescuer moves up and down on the mini-haul.

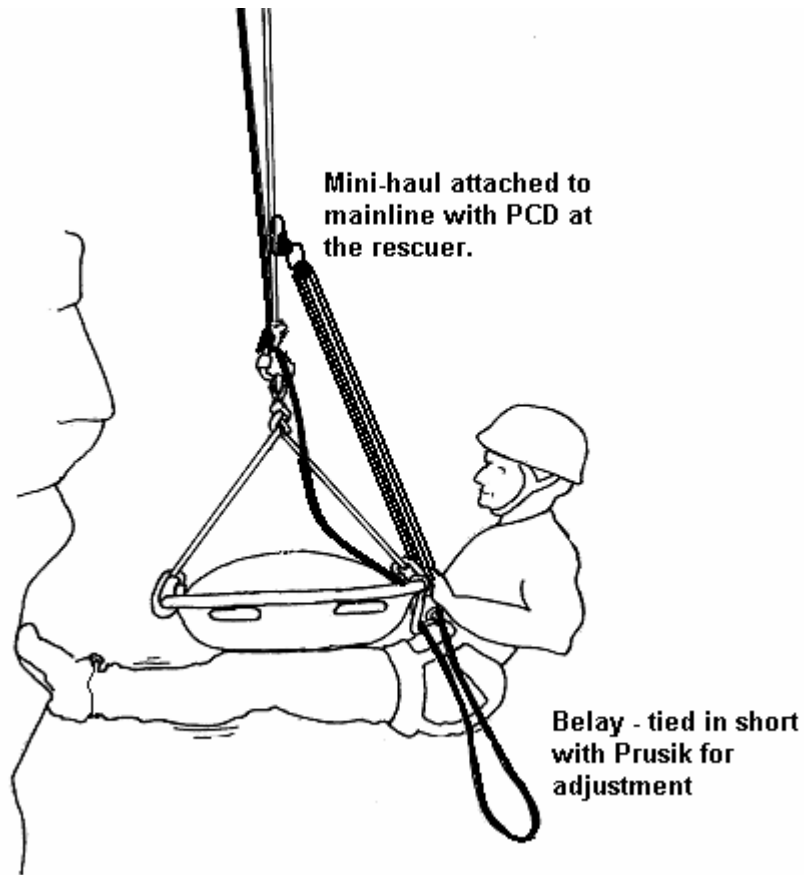

For the attendant to perform their duties, the best posture is a natural one for sitting in seat harness. For horizontal litter orientation the attendant should position themselves below the litter with the litter a few inches above their lap. The litter should not rest on the attendant's lap or legs. This will restrict movement. The attendant should grasp the mainframe at the closest rail to help maneuver the litter. If the litter is against the wall, the attendant should place their feet against the wall to gain some leverage to pull the litter away from the wall by grasping the nearest rails. This will keep the litter from bumping against the wall and snagging.



The attendant's position will vary when encountering lips or undercuts.

- The attendant will need to be above the basket when transitioning an undercut.
- The attendant will need to be below the basket when transitioning a lip.

For vertical litter orientations, the attendant should position themselves along side or straddle the litter.

For horizontal litter orientations, if the attendant needs to roll the patient (such as to clear the airway), the litter can be rolled toward the attendant.

- The attendant reaches across with one hand, grasps the opposite rail, and pulls it over toward the attendant to roll the litter and patient.

---

## Vertical Operations

---



## Chapter 6: Mechanical Advantage

---

### Terminal Performance Objective:

Given classroom instruction, demonstration, and general equipment likely to be used in a technical rescue incident, the student will be able to build and operate 3 types of simple mechanical advantage systems likely to be used in a technical rescue with 100% accuracy according to skills check-off criteria.

### Enabling Objectives:

- Identify general rules specific to simple mechanical advantage rope systems.
- Build and operate a 2:1, 3:1, and 4:1/5:1 Block and Tackle.
- Assess where the best placement for a progress capture devices would be located.
- Direct the team in the operation of a simple mechanical rope system.
- Discuss factors that may affect the efficiency of a mechanical advantage rope system.

## Work and Mechanical Advantage

Man first started using machines to make work easier and faster. How much easier and faster a machine makes your work is the mechanical advantage of that machine. In science terms, the mechanical advantage is the number of times a machine multiplies your effort force. Let's look at some types of simple machines that make our job easier...

A Lever is a simple machine consisting of a rigid bar that rotates about a fixed point, called a fulcrum. Levers affect the effort, or force, needed to do a certain amount of work, and are used to lift heavy objects. To move an object with a lever, force is applied to one end of the lever, and the object to be moved (referred to as the resistance or load) is usually located at the other end of the lever, with the fulcrum somewhere between the two. By varying the distances between the force and the fulcrum and between the load and the fulcrum, the amount of effort needed to move the load can be decreased, making the job easier.

Physicists classify the lever as one of the four simple machines used to do work. (The other three are the pulley, the wheel and axle, and the inclined plane.) Work is defined in physics as the result of a force, such as a person lifting that moves an object over a distance. A common example of a lever is the seesaw. The human arm is also a lever, where the elbow is the fulcrum and the muscles apply the force.

A lever makes work easier by reducing the force needed to move a load. Work, in physics, is the product of the force used to lift a load, multiplied by the distance the force, or effort, is applied. This relationship can be written mathematically as:

$$\text{Work} = \text{Force} \times \text{Distance}$$

The amount of work needed to move an object a given distance always remains the same except when friction is present. The lever, like all simple machines, makes doing work easier by reducing the force needed to move an object. In order to reduce the force needed, the distance over which the force is applied must be increased.

To increase this distance, the load to be moved must be close to the fulcrum and the force must be applied far from the fulcrum. A good example is a seesaw. The force of a smaller person can balance and even lift the load of a larger person as the smaller person moves farther away from the fulcrum.

The mechanical advantage (MA) of a lever tells how much the lever magnifies effort. The greater the MA, the less the effort needed to move a load. The MA of a lever is the ratio of the distance the force travels to the distance the load travels. In practical terms, the MA is the distance of the force to the fulcrum divided by the distance of the load to the fulcrum. Depending on the class of lever and the location of the fulcrum, the MA may be less than or greater than 1.

## Types of levers

There are three different classes of levers, depending on the arrangement of the force, the load, and the fulcrum along the lever bar. Each class of lever affects force in a different way, and each class has different applications.

The class 1 lever has the fulcrum between the force and the load, as in a seesaw. When two people of equal weight use the seesaw, they position themselves an equal distance from the fulcrum, and the system is balanced. When a heavier person sits on one end, that person usually moves toward the center, which gives a mechanical advantage to the lighter person so that the system is again in balance. It is possible for a class 1 lever to have a significant mechanical advantage.

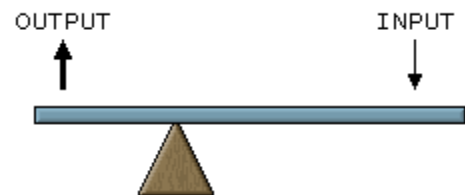

The class 2 lever has the fulcrum at one end, the force at the other end, and the load in the middle. A common example is the wheelbarrow, where the wheel is the fulcrum, the load rests within the box, and the force is the lift supplied by the user. A class 2 lever always has a mechanical advantage of greater than 1. To reduce the force required by the user even more, the best wheelbarrow design is one where the wheel is directly under the load, reducing the distance from the load to the fulcrum almost to zero.

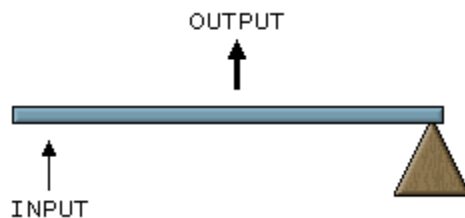

A class 3 lever has the fulcrum at one end, the load at the other end, and the force in the middle. The human forearm is a class 3 lever. The class 3 lever always has a mechanical advantage of less than 1, because the load travels a greater distance than the force travels. Consequently, the work requires more effort than would ordinarily be needed. Although they boost the amount of effort needed, class 3 levers are useful for increasing the speed at which a load is moved. A baseball bat and an aerial device are also examples of class 3 levers, with which a greater effort results in a smaller load moving at a greater speed.

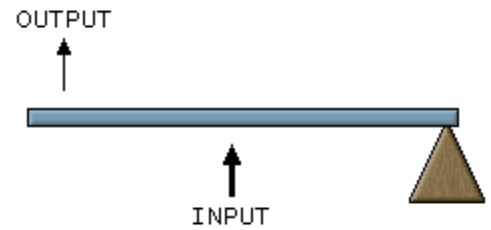

## Inclined plane

An **Inclined plane** or a ramp is one of the basic machines. It reduces the force necessary to move a load a certain distance upward by providing a path for the load to move at a low angle to the ground. This lessens the needed force but increases the distance involved, so that the amount of work stays the same.

Examples are ramps, sloping roads, chisels, hatchets, plows, air hammers, carpenter's planes and wedges. The inclined plane is used to reduce the force necessary to overcome the force of gravity when elevating or lowering a heavy object. By changing the angle of the ramp one can usefully vary the force necessary to raise or lower a load. The most simplistic example of an inclined plane is a sloped surface; for example a roadway to bridge a height difference. The ramp makes it easier to move a physical body vertically by extending the distance traveled horizontally (run) to achieve the desired elevation change (rise).

In civil engineering the slope or ratio of rise/run is often referred to as a grade or gradient. Others may also call it tilt.

Other simple machines based on the inclined plane include the blade, in which two inclined planes placed back to back allow the two parts of the cut object to move apart using less force than would be needed to pull them apart in opposite directions.

### THE INCLINED PLANE

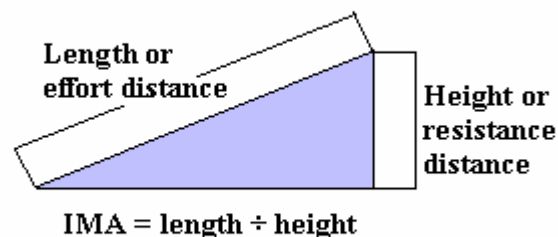

If an object is put on an inclined plane it will move more easily if the force of friction is decreased. This can be accomplished by simply putting sand, or by using a liquid to make the surface slick, between the surface of the inclined plane and the load.

## Mechanical Advantage and Ropes

Conditions can change through the course of raising a load; steepness of terrain may change, more haulers become available, more ropes become available as the load is raised, or a knot may have to be passed. Efficiency is achieved by having knowledge and skill to be flexible enough to recognize what practical and simple changes can be made during an operation when the conditions change. Knowledge provides understanding, skill provides ability, practice provides proficiency, and from these, together with experience, comes judgment.

### Mechanical Advantage and Ropes - Terminology

- **Mechanical Advantage (M/A)** - force created through mechanical means, including but not limited to a system of levers, gearing, or ropes and pulleys; usually creating an output force greater than the input force and expressed in terms of a ratio of output force to input force.
  - Ideal M/A - what the MA would be in a world without friction.
  - Theoretical MA - MA is calculated when predicting the friction loss due to pulleys
  - Actual MA - the true resultant of mechanical advantage under full operation. Measured under working conditions.
- **Traveling (Moving) Pulley** - a pulley, in a system that *moves with the load*, also called a *movable pulley* and will create mechanical advantage. The movable pulley reduces the effort required to lift a load.
- **Stationary (Fixed) Pulley** - a pulley in the system that does not move with the load also called a *static pulley*; it will be attached to an anchor and will not create mechanical advantage. The same amount of force is still required, but may be applied in another direction. The main benefit of a static pulley is that it changes the direction of the required force.
- **Pulley System** - combination of fixed and traveling pulleys and rope used to create mechanical advantage.
- **Progress Capture Device (PCD)** – a prusik or cam utilized to hold the load while the system is reset and to catch the load if the haul team should stumble, etc. May also be called a “ratchet” or “brake.”
- **Haul Cam** - a prusik or cam used to grab onto the rope which is extended to the load. It serves as a point of purchase for the haul system to pull.
- **Throw Distance** - the distance that a pulley system collapses between resets.
- **Reset** - as a pulley system is pulled on, it collapses to the point where one (1) or more of the traveling pulleys meet the stationary pulleys. At this point the load cannot be pulled up any further. The term reset describes the act of re-expanding the pulley system to its original dimension so that pulling may continue.
- **Two-blocked** – during hauling operations this term is used to describe when the traveling pulleys, in a MA system, have collapsed into the fixed pulleys, requiring a reset.
- **Piggybacking** - a method of attaching one pulley system onto another, or attaching an independent pulley system onto a static line.

## Types of Mechanical Advantage Systems

Rope and pulley systems fall within three categories, **simple**, **compound** or **complex**. Each category has criteria to follow when identifying a mechanical advantage system. Most pulley systems can be rigged either by using the mainline itself or using a separate rope, which attaches to the mainline. While most pulley systems used in rope rescue will be either simple or compound, rescuers still need to be able to recognize and understand the advantages and disadvantages of all types of pulley systems. Compound and Complex MA will be discussed and applied in the Rope Techniques Program.

### Rules for Simple Systems

- Constructed from one (1) rope
- The system contains one (1) or more moving pulleys
- All the traveling pulleys move toward the anchor at the same rate/ speed
- All traveling (moving) pulleys result in mechanical advantage
- Fixed pulleys attached to the anchor only change the rope's direction (they do NOT add mechanical advantage)
- If the rope end/ knot is attached to the load, the IMA is "odd" (e.g. 3:1, 5:1)
- If the rope end/ knot is attached to the anchor, the IMA is "even" (e.g. 4:1, 2:1)
- You count the number of support lines attached to the load to determine the Ideal Mechanical Advantage

## Mechanical Advantage System Components

### Stationary Pulley

The picture aside illustrates a stationary pulley. It is fixed, in that the pulley doesn't change position when the rope is pulled. The tension on the rope is equal to the weight of the object. This tension is the same all along the rope. In order for the weight and pulley to remain in equilibrium, the person holding the end of the rope must pull down with a (input) force that is equal in magnitude to the tension on the rope. The input force is equal to the weight, as shown in the picture.

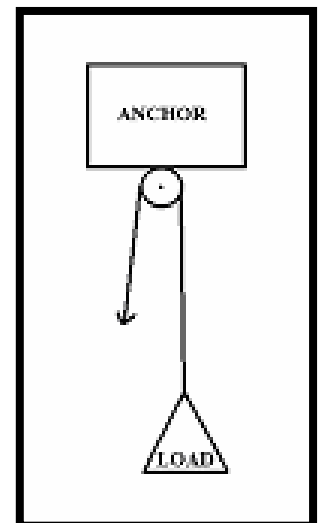

### Traveling Pulley

A traveling pulley refers to a pulley that changes position, or moves, when a haul is initiated. As the rope is pulled up, the pulley also moves up. The load is supported by both the rope end attached to the anchor and the end held by the person. Each side of the rope is supporting the weight, so each side carries only half the weight. The force needed to move the pulley attached to the load in this example is  $\frac{1}{2}$  the weight. The mechanical advantage of this system is 2 (two).

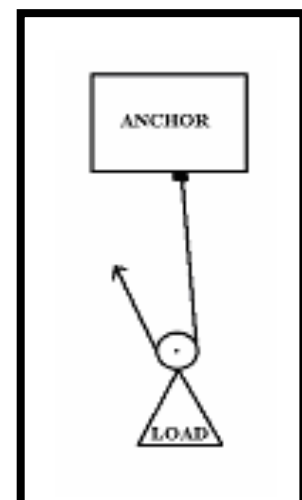

How long does the rope have to be?

The amount of rope required to haul a load a given distance is determined by the systems IMA. If the IMA is 2:1 then the team will have to pull 2 feet of rope for every 1 foot the load travels. Likewise, a 6:1 IMA system will require 6 feet of rope to be hauled to move the load 1 foot.

This information can be important in determining the type of MA system your team will construct and use based on the amount of available rope and equipment.

Identify the mechanical advantage of these simple systems:

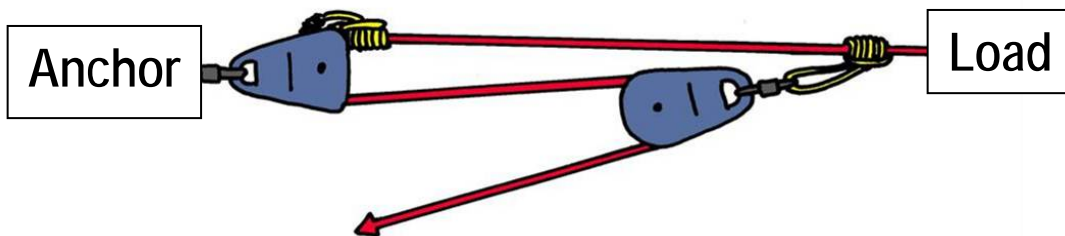
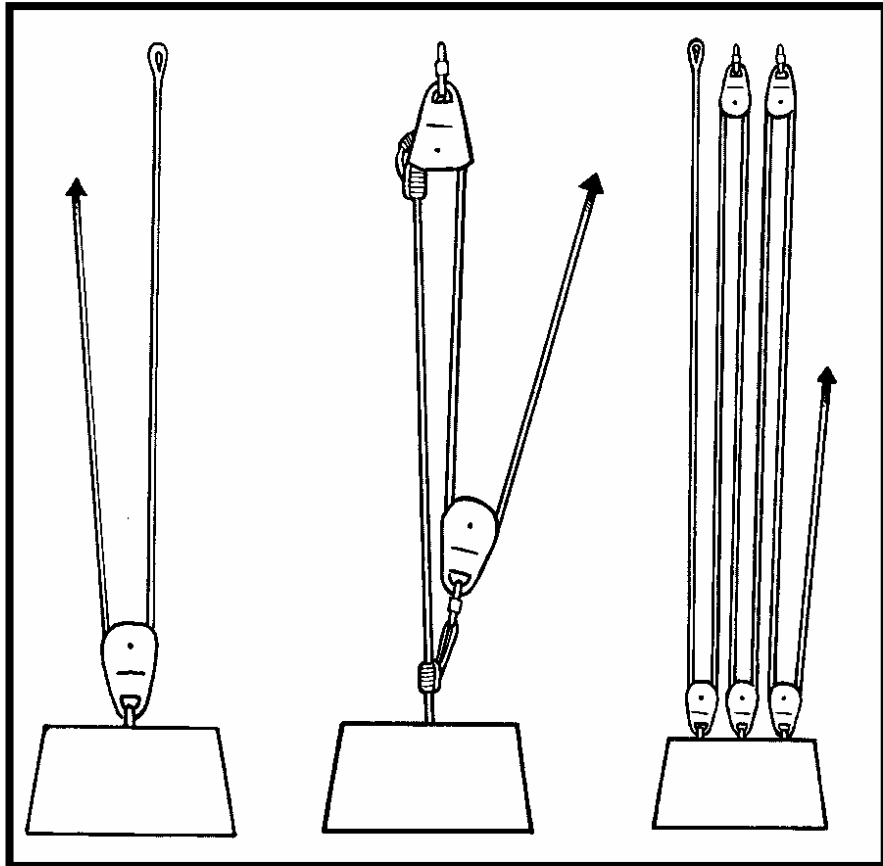

Exercise: Answer the following mechanical advantage problems using any/all the methods of determining mechanical advantage, identify the type of system, and note if a change of direction is used.

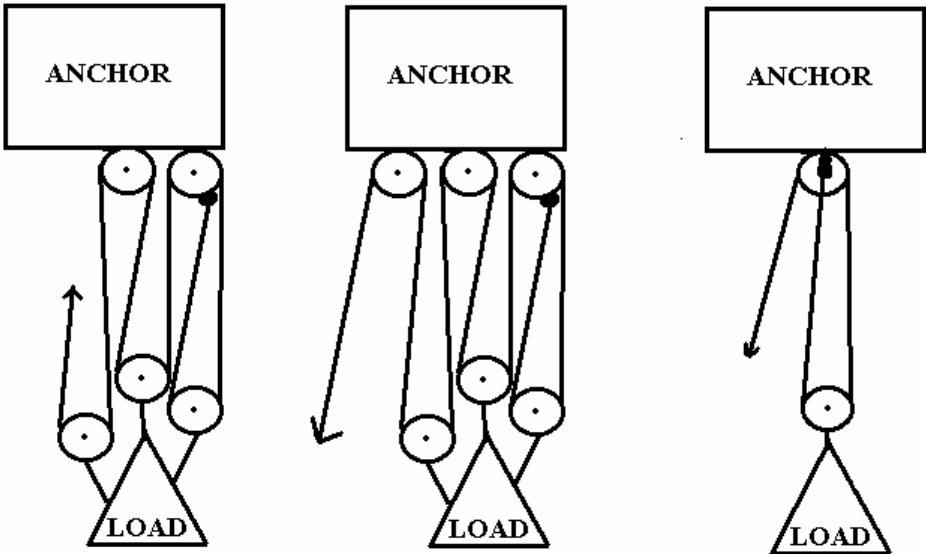
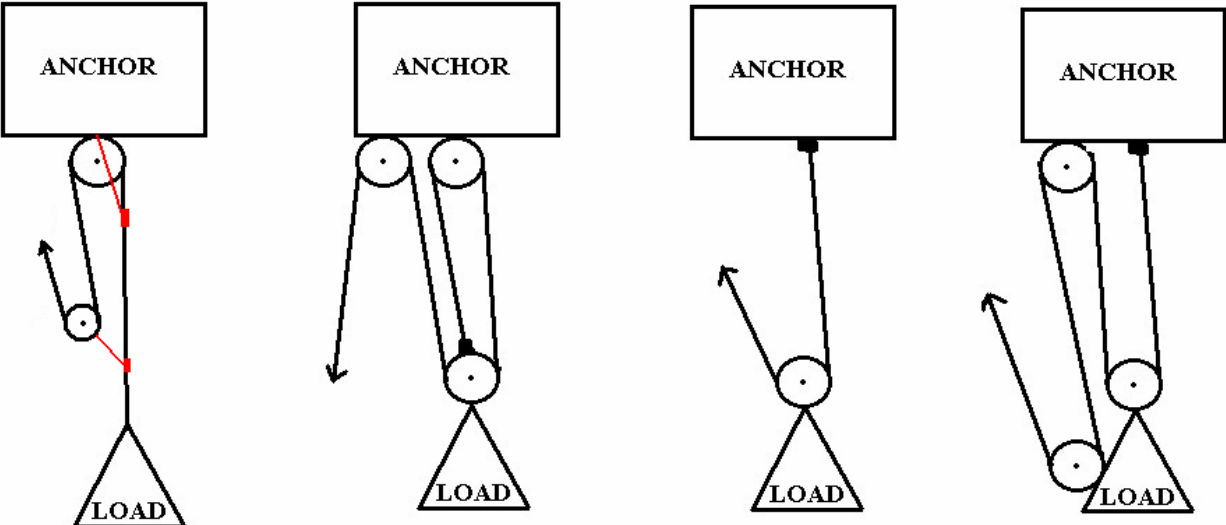

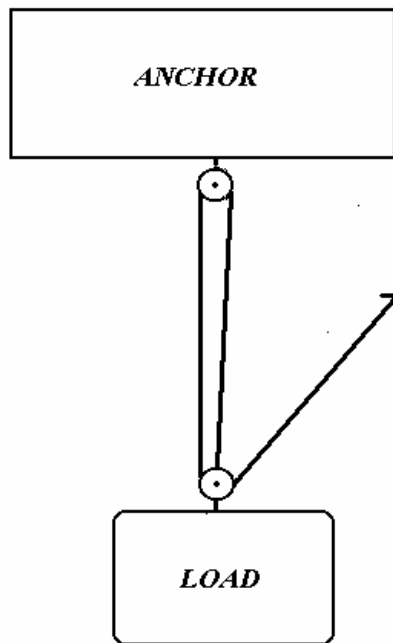
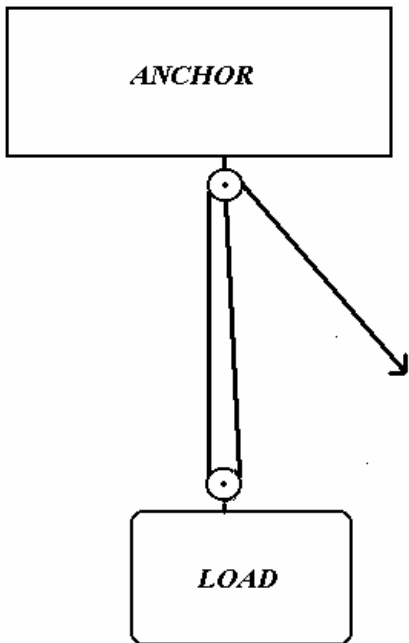
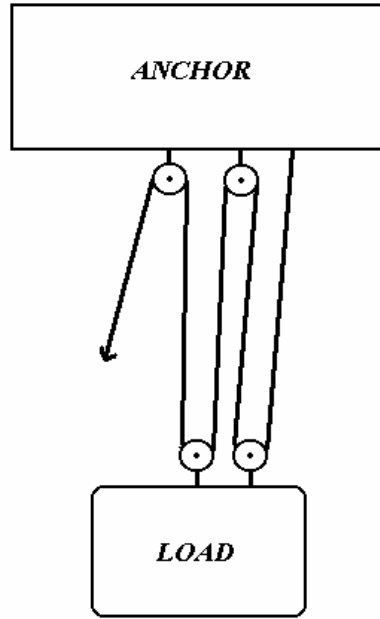
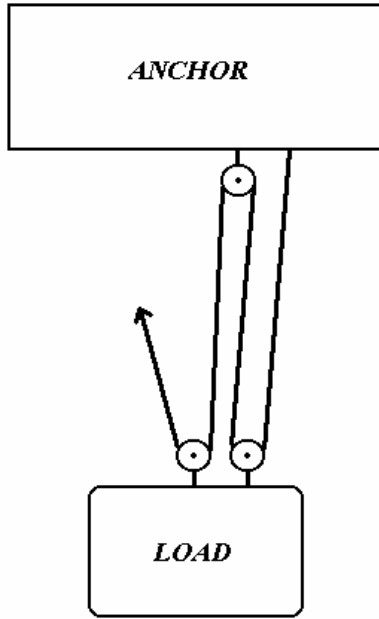

## Pulley Efficiencies

The more efficient pulley should be placed at the \_\_\_\_\_ side of the MA system.

The type of pulleys used can dramatically affect the mechanical advantage of a system when in operation. The size of the pulley, type of bearing and the condition of the pulley area are a few of the factors to consider when choosing a pulley.

### Size of pulley - 1", 2", 4"?

Smaller sheaved pulleys are lighter, easier to carry, but result in more friction. Larger sheaved pulleys are heavier and more expensive. Larger pulleys are considered more efficient because they reduce internal rope friction. Larger pulleys also help in retaining most of the rope's original strength.

- 4 times the diameter of the rope is good for rescue (on nylon)
- 4 X ½" rope diameter = 2" sheave size

Know your sheave size. Most 2" pulleys are really 1-1/2" when you measure the diameter of the sheave channel. Pulley sheaves are made for certain sizes of rope. Sheaves that are too narrow will cause the rope to bind between the side plates.

### Specialty Pulleys

Double pulleys are used to replace 2 pulleys in MA systems that require 2 pulleys at one end of the system. One example is a simple 4:1. Often, placing two single sheave pulleys side by side in a carabiner will result in each pulley being canted to the side, resulting in added friction due to the rope rubbing against the side plates of the pulleys. The use of a double sheave pulley will prevent this from occurring. However, the use of double sheave pulleys can inhibit changing MA or passing knots during an operation.

Knot passing pulleys have a wide sheave and longer side plates which allow knots to pass through pulley. It's best to limit the need to pass knots during rescue operations because of time consumption. It's always better to rig your systems where there is no need to pass a knot through the MA system.

## Pulley and Carabiner Comparison

The choice of the equipment used in a mechanical advantage system can drastically change the efficiency of the system. To determine the THEORETICAL MA you need to multiply IDEAL MA by the percentage of efficiency of each pulley, or carabiner, that the rope contacts throughout the system.

- Sealed ball bearing (2" is about 95% efficient).
- Non-sealed bushing requires oiling and cleaning (2" is about 75% efficient).
- Full of dirt? This can drop pulley efficiency to 50% or less.
- A carabiner is rated at about 66% or 2/3 efficient. (Poor choice).

The chart below compares the ideal MA, vs. theoretical MA, when using pulleys and carabiners.

System constructed with:	Ideal M/A	Efficiency Factor	Theoretical M/A
Carabiners (½" Dia.)	3:1	≈ 0.66	2.09
Oilite Pulleys	3:1	≈ 0.75	2.31
Ball bearing Pulleys	3:1	≈ 0.95	2.85
Frictionless	3:1	1.00	3:1



## Chapter 7: Vertical Haul Systems

---

### Terminal Performance Objective:

Given classroom instruction, demonstration, rescue scenarios, and general equipment likely to be used in a technical rescue incident, the student will be able build and operate a vertical haul system likely to be used in a technical rescue with 100% accuracy according to skills check-off criteria.

### Enabling Objectives:

- Identify the components of a haul system.
- Build and operate a vertical haul system.
- Demonstrate proper commands when operating a vertical haul system.
- Perform a system safety check.
- Discuss environmental factors that may affect the choice of system and efficiency of a haul system.

### Terminal Performance Objective:

Given classroom instruction, demonstration, a loaded raising and/ or lowering system, and auxiliary rescue equipment, the student shall safely demonstrate changing the systems components to affect the direction of travel of the load with 100% accuracy according to skills check-off criteria

### Enabling Objectives:

- Identify the need to perform a system changeover while under tension.
- Discuss the procedures for changing loaded rope system components to function from a lower operation to a raise operation and visa versa.
- Demonstrate changing over the system from a raising system to a lower system.
- Demonstrate changing over the system from a lower system to a raising system.

## Considerations for Rigging Haul Systems

The team must first consider the anticipated load, number of available haul team members and the environment that rescuers will be working in. This will determine the IMA that the team will use. If possible rig where the haul team has room to work and can use gravity to their advantage (use a change of direction if needed). Rig where haul team can work and move safely. Avoid over-rigging— use the least complex system that will do the job.

Be sure to give the litter room for a good “landing.” Ten foot of landing space is a good objective but you’ll have to take what you can get in some confined space settings.

Minimize friction in your haul system and protect the rope at friction points. This will become extremely important for operations where equipment and/ or manpower are limited.

Make your system as efficient as possible. Use compact knots (short bights) to maximize the use of height advantage. Rig to maximize your systems throw (haul distance) to minimize the number or resets.

STOP when you feel abnormal resistance in your haul system. You can easily overload the system by adding more haul team members. Look for and fix the friction problems, consider lightening the load, or change system components. Once this is done, then add more haulers carefully and thoughtfully! You only need to have enough haulers to move the load with some resistance. Adding too many haul team members can result in overstressing the system.



## Managing the Edge

Litter orientation will be based on a few factors. Patient condition or anxiety, obstacles, the availability of height advantage and edge transition problems are a few points to consider. Litters rigged in vertical orientation will facilitate easier edge transitions where no high help exists. Most victims will be apprehensive and are more comfortable taking the ride in a litter that is horizontal. Use taglines to control the litter if they are feasible. Litter attendants only add weight to the system and complicate operations. Look for an alternative to litter tending if the situation allows.

Use of edge tenders can be helpful for large loads or tough edge transitions. Edge tenders may require fall protection for edges without parapet walls or substantial hand rails.







High help will provide for ease of launch or reception of the load. High help or high directionals are for the mainline ONLY. The belay should run along the natural ground to provide the highest level of protection for the load.



## Calling commands

Generally, one person should be assigned to call the commands. That person may vary depending on the situation. A litter with patient should only move when the litter attendant (and patient) is ready. The Haul, Set, Reset series of commands may be issued by different persons on the haul team, depending on who can best observe the need for the next stage in the hauling process. Some situations require the placement of an individual between the edge manager and the operation team to relay commands. High noise environments may require the use of hand signals or whistle signals to relay operational commands. In either case all affected team members will need to be briefed prior to the start of an operation whenever abnormal communication procedures are used.

Some hand signals used in rope operations:

- Closed fist – STOP 
- Thumb up – OK, Affirmative 
- Thumb down – Negative 
- Index finger up, circle motion – Up, Haul (faster circular motion = Up fast) 
- Index finger down, circle motion – Down, Lower (faster circular motion = Down fast) 
- Index finger intermittently touching Thumb – Small increment, a little bit, real slow 

Some whistle signals used in rope operations:

S – Stop = One Blast

U – Up = Two Blasts

D – Down = Three Blasts

O – Off rope = Four Blasts

T – Trouble = Continued (LONG) Blast

When do you redo a roll call? The operation should not begin until ALL participants are ready. There is no need to continue roll call if someone is not prepared. Once roll call is complete and the operation begins, all participants should have 100% of their attention on the operation. Should a “stop” be called, there is no need to revisit roll call unless an extended period of time passes.

# Lowering Operational Commands

	Command	Response
Roll Call	Belay Ready?.....	Ready on Belay! (device unlocked and in hand) or Standby! (give indication of time needed)
	Mainline Ready?.....	Ready on Mainline! (device unlocked and in hand) or Standby! (give indication of time needed)
	Edge Ready?.....	Ready on Edge!
	Rescuer Ready?.....	Rescuer Ready!
Positioning the Load	Load the System! (out to plumb point or prep for edge transition) Slack on Mainline! (if needed to approach the edge, as necessary) Tension on Mainline!(if slack was given during edge approach)	
Tensioning the system	Vector Mainline! (1 or 2 people deflect the mainline, and no rope is let through the rack.) Release Vector! (slowly) Line is loaded! Lower on Mainline!.....Lowering on Main!  *Rescuers needs: Commands should be specific to the needs of the attendant, such as speed, belay, and indication of progress.	
Termination	Rescuer on the Ground! Off Mainline! Off Belay! (free and clear of drop zone)	
Additional Commands	Stop, Stop, Stop!!! (can be given by anyone, it means 'freeze') Tension (too much slack, take up) Slack (too much tension, need more rope). Rig for Raise! (initiate change from lower to raise).	

# Hauling Operational Commands

	Command	Response
Roll Call	<p>Belay Ready?.....</p> <p>Mainline Ready?.....</p> <p>Edge Ready?.....</p> <p>Rescuer Ready?.....</p>	<p>Ready on Belay! (device unlocked and in hand) or Standby! (give indication of time needed)</p> <p>Ready on Mainline! (Haul team in position) or Standby! (give indication of time needed)</p> <p>Ready on Edge!</p> <p>Rescuer on Belay &amp; Ready for Raise!</p>
Positioning the Load	<p>Load the System! (out to plumb point or prep for edge transition)</p> <p>Slack on Mainline! (if needed to adjust position of the load, as necessary)</p> <p>Tension on Mainline! (if slack was given)</p>	
Tensioning the system	<p>Tension on Mainline! (1 or 2 people deflect the mainline, and no rope is let through the rack.)</p> <p>Haul on Mainline! (slowly)</p> <p>Stop – Set – Reset – Haul (to be determined by haul team. DO NOT REDO ROLLCALL. Operation carries on)</p> <p>*Rescuers needs: Commands should be specific to the needs of the attendant, such as speed, belay, and indication of progress.</p>	
Termination	<p>Load at the Edge! (stop – set – reset for final haul, as necessary)</p> <p>Load on the ground!</p> <p>Off Mainline!</p> <p>Off Belay! (free and clear of drop zone)</p>	
Additional Commands	<p>Stop, Stop, Stop!!! (can be given by anyone, it means ‘freeze’)</p> <p>Tension (too much slack, take up)</p> <p>Slack (too much tension, need more rope).</p> <p>Rig for Lower! (initiate change from lower to raise).</p> <p>Reverse Haul! (used to initiate the reversal of the mechanical advantage system to lower the load)</p>	

## Changeover Loaded Systems

During a rope rescue the need may arise to change the system from a lower to a haul, or visa versa, while the system is under tension. A team based pick-off of a stranded or injured victim is one example of a need for this particular skill.

Changeover considerations:

- The changeover should be expected. If lowering to a stranded conscious victim, prepare for them to suddenly grab the rescuer or load onto the system.
- Increased load (taking on another person) will result in a potential need for higher MA or increased friction in the descent control device.
- Pre-rig or place equipment at the system anchor in preparation for the changeover.
- Rigging plates or rings used at the mainline anchor may aid in changeover efficiency.

Procedure for changeover - Lower system to haul system

- Lower the load to position. Hold stop or lock-off on all bars.
- Double up a short length of webbing and attach to the mainline anchor. Make sure the webbing is long enough to extend past the rack and secure it to the mainline with a prusik.
- Safety check the newly established PCD.
- Lower the load onto the extension until there is enough slack to de-rig and remove the rack.
- When changing to a 3:1 Z-Rig replace the rack with a directional pulley and PCD. Finish the Z-Rig with the MA pulley and haul cam. Complete system safety check. You are ready to haul (remove the extended PCD and webbing as necessary).
- OR, if you are using a piggyback system for hauling, you can simply attach your MA block and tackle system onto the mainline, using the extended PCD as your system PCD.

Procedure for changeover - Haul to Lower with Z-Rig

- Haul the load to position. Set the PCD in your haul system.
- Option # 1 - Bypass the system PCD with a partially collapsed mini-haul attached to the mainline anchor. Attach the mini-haul to the tensioned mainline. Perform safety check of the mini-haul. Haul on the mini-haul resulting in slack on the systems PCD. Set the mini-haul PCD. The mini-haul now has the load. Remove the haul system components and rig the rack behind the mini-haul. Rig all bars on the rack and hold stop or lock-off. Safety check the rack and system components. Haul slightly on the mini-haul to release its PCD. Reverse haul on the mini-haul until the load is held by the rack. Slacken the mini-haul and begin lowering on the haul line to confirm proper rigging. Release the mini-haul from the mainline and continue the lower
- Option # 2 - Bypass the system PCD with a doubled up short length of webbing attached to the mainline anchor. Extend the webbing past the systems PCD and secure it to the mainline with a three wrap prusik. Safety check the newly established PCD. Haul on the mainline to release tension on the mainline's PCD. "SET" the extended PCD while you haul on the system. Be sure to "mind" the systems PCD to obtain slack on the systems PCD. The PCD on the webbing extension now has the load. Remove the haul systems directional pulley and PCD. LEAVE THE MA PULLEY ATTACHED TO THE MAINLINE. Rig the rack behind the PCD extension. Rig all bars on the rack and lock-off. Safety check the rack and system components. Haul on the systems MA resulting in slack at the extended PCD. "Mind" the PCD while you reverse haul until the load is held by the rack. Remove the MA pulley and rope grab from the mainline. Begin lowering on the haul line to confirm proper rigging. Release the extended PCD from the mainline and continue the lower

## Changeovers in piggybacked systems

Changeover is much simpler when a MA system is piggybacked onto the mainline because it takes less time and minimal equipment is required. The PCD is already in place and slack can be provided by the tensioning of the MA system, allowing the descent control device to be placed behind the systems PCD.



# Chapter 8: Slope Haul Systems

## Terminal Performance Objective:

Given classroom instruction and general equipment likely to be used in a technical rescue incident, the student will be able to evacuate a patient from sloped terrain without further injuring the patient or rescuers, with 100% accuracy according to skills check-off criteria.

## Enabling Objectives:

- Identify dangers of slope operations.
- Discuss when rope system(s) are needed in a sloped environment.
- Demonstrate tending a litter in a sloped environment.

## Terrain Evaluation

- Designate a few rescuers to scout ahead to clear terrain and debris as needed if possible.
- Medical care should be given to the patient during evacuation.
- Determine the consequences of moving on sloped terrain.
- Examine the risk involved in the environment to determine if a belay is needed or if a mainline and belay are needed.

Within the state of Georgia many rescues occur in areas where patients can be transferred to the transport vehicle on a rolling, wheeled stretcher over pavement or, at worst, by performing a flat carry of a patient for a short distance on a backboard or in a basket stretcher.

However, rescuers can become conditioned to using these transfer mediums and may attempt to use these techniques in inappropriate circumstances, with less than desirable results. The slope of terrain and the condition of the walking surface have a similar impact on the need for rope systems to support patient transfer operations. Likewise, a degree of technical expertise is required to construct and manage such a system.

Rescuers may carry a basket stretcher up small rise with little or no difficulty under dry weather conditions but find the same slope almost impossible to climb after periods of rain or snow. Therefore, knowledge of how to read and anticipate the impact of angle of terrain under varied weather conditions is essential to a successful patient transfer operation.

Flat terrain - 0 - 15 degrees off of a horizontal plane (see diagram)

Carries require five to six litter tenders walking upright with one foot in front of the other and scouts ahead of the litter bearers to select a route of travel, warn of obstacles and hazards in the path, and assist with passing over any obstacles encountered.

No external rope systems are required. Footing is adequate for balance such that litter bearers can focus on carrying the litter, without fear of dropping it, instead of using their hands to reach for handholds and struggling to maintain balance and footing.

No tie-ins are required for tenders. Since the litter tenders are able to walk upright with one foot in front of the other, tenders have no need to be tied to a system to help them walk or to maintain balance and footing.

Litter tenders carry around 100% of the rescue load instead of having the load partially or completely supported by a rope.

Risk of falling injury is minimal. Aside from normal risks of tripping and falling, there is no significant threat of a fall at this inclination.

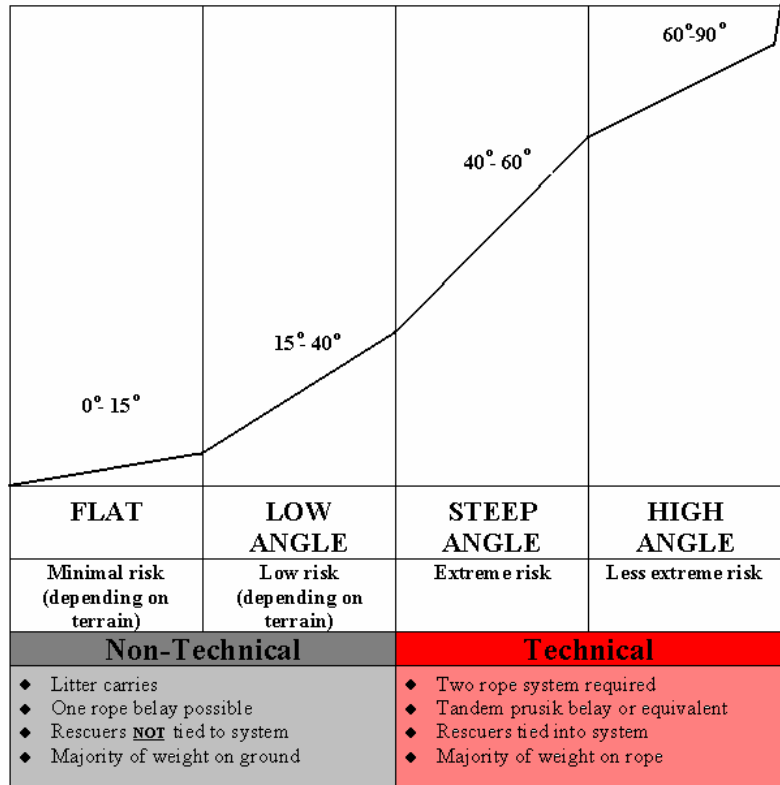

Low angle terrain - 15 - 40 degrees off of a horizontal plane (see diagram)

Carries require five to six litter tenders walking upright with some degree of difficulty due to the incline. Litter tenders may have a need to side step or walk in a slightly forward leaning attitude to aid in balance and footing.

A belay line attached to the litter is required for added safety. As the difficulty of walking increases, the need to use hands and careful foot placement also increases. In these circumstances, a safety line or belay may be desirable in the event that the litter is dropped.

No tie-ins are required for bearers. Since litter bearers are, for the most part, able to walk without reaching for handholds, they do not have a need for a rope system to protect them from falling or to assist with moving the litter uphill.

Anchor system for the belay line is required. The use of a simple anchor system is adequate for this minimal loading application.

Litter tenders carry 100% of the rescue load as they did on flat terrain. With an increase in the angle of inclination, there is some risk of minor injury as a result of falls.

Steep angle – 40 – 60 degrees (see diagram)

Carries require three to four litter tenders walking upright with a little more degree of difficulty due to the incline. Litter tenders may have a need to walk in a slightly leaning back into the system to aid in balance and footing.

A belay line attached to the litter is required for added safety. As the difficulty of walking increases, the need to use hands and careful foot placement also increases.

In these circumstances, tie-ins are required for tenders. Since litter tenders are, for the most part, leaning back into the rope system and allowing the rope to carry the load there is a need for two lines attached to the litter. This can be in the form of a drop loop system. Where as each line supports only ½ of the total load. A belay may also be considered depending on circumstances and the outcome of an unforeseeable system failure.

Always use a strong and sound anchor system. This sort of system can create high forces at the anchor. With an increase in the angle of inclination, there is extreme risk of major injury as a result of falls. Therefore there is the need for a two rope system. Rope carries close to 100% of the rescue load, plus the litter tenders.

High angle (vertical) - 60 - 90 degrees (see diagram)

Use high angle rescue techniques taught for this degree of terrain. Limit the number of litter bearers to a minimum of 3 and consider the use of separate rope systems and belays for both the litter and litter team members.

### Rigging the Litter for Sloped Terrain

The litter will be rigged for vertical using techniques taught in this course. The secondary attachment on the litter bridle can be used of a belay attachment or simply tucked away if a belay is not needed for the litter.

### Hauling the Litter in Sloped Terrain

#### Litter ascent using a “Caterpillar Pass”

- This method is used on slopes where no rope systems or only a single belay system are necessary.
- Position sufficient rescuers on both sides of the basket stretcher facing each other.
- Rescuers carefully lift the basket and pass the basket up the slope.
- As the basket leaves the hands of the rescuers that are positioned farthest down the slope they climb to a position at the head of the line, closest to the top of the slope, to receive the litter and pass it on from that position.
- If a belay is being used, slack is taken up as the basket ascends the slope.

#### Litter ascent using a 1:1 counter balance system

- Establish a belay line if needed using adequate anchor system.
- Attach a separate haul line with anchor to the head of the basket.
- Place a PMP (prusik minding pulley) at the anchor and run the rope through it.
- Using sufficient rescuers to carry the basket, on command from the litter captain, all necessary/available personnel pull the rope down the slope as the basket and bearers move up the slope. This must be a smooth pull to avoid patient discomfort.

### Litter ascent of a slope using a 3:1 z rig

- Rescuers at the top of the embankment lock off the lowering system and change to a raise system using a 3:1 mechanical advantage hauling system.
- The rope of the first rescuer down the slope is changed to a belay.
- The litter bearers, one each at the three o'clock, nine o'clock, and six o'clock positions lift the basket, lean back, and allow the hauling system to pull them up.

### Communications during litter slope evacuation evolutions:

The Control is responsible for the communications for the lower operation. This person relays messages to and from the rescuer and other team members. However, when hauling up the embankment, one of the litter tenders must be in charge of the "HAUL" command.

### Litter bearer attachment methods

The methods of attachment of the litter bearers will depend on the level of inclination and the number of litter bearers to be used. Generally, no more than 4 litter bearers are required to safely lift and transport the load. 3 litter bearers will usually suffice for the majority of slope operations. In either case, the decision on the number of litter bears and the haul system to be used will be based on the degree of inclination.

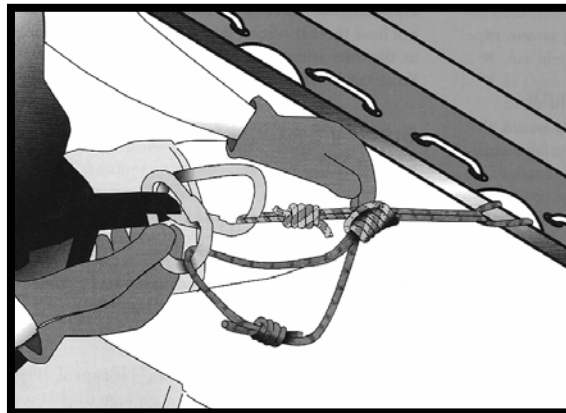

(Picture source: HART- Hudson/ Vines)

In all cases, the litter bearer will attach themselves to the litter's mainframe by using a long and short prusik, hitched together, or the short Purcell prusik from their personal climbing system (if available). The long prusik is hitched or girthed around the mainframe, at the point where the litter bearer will position themselves for the carry. The short prusik is hitched around both strands of the long prusik and both prusik bights are attached directly to the litter bearer's harness with a carabiner. Adjustment is achieved by sliding the short prusik up or down along the long prusik. Additional adjustments can be made by making additional wraps around the hand rail with the long prusik or around the carabiners spine with the short prusik. The Purcell prusik is attached by girth hitching the bight to the mainframe and attaching the foot-loop to the bearers harness. The foot-loop can be easily adjusted to take up, or let out, the distance between the bearer and the litter.

A second point of attachment is not required of each litter bearer if a belay is attached to the litter. The mainframe of any reputable litter manufacturer is sufficient to support the load of each litter bearer in a slope operation.

## Chapter 9: Portable Height Advantage

---

### Terminal Performance Objective:

Given classroom instruction, demonstration, a tripod and rescue equipment, the student will be able build and use at least two types of portable height advantage likely to be used in a technical rescue with 100% accuracy according to skills check-off criteria.

### Enabling Objectives:

- Construct a Ladder Gin.
- Construct a Ladder A-Frame.
- Demonstrate proper techniques for the set up and use of a commercial tripod.
- Identify at least three advantages of using “high help” of any sort of height advantage.

The edge is routinely the most difficult area to maneuver and typically has some sort of obstacle to overcome. Gaining height advantage at the edge makes for a smoother and easier edge transition. Using a commercial tripod is one option, but if a commercial tripod is not available, then constructing a form of a monopod, bipod or tripod could be another choice.

The forces generated and applied must be understood when suspending loads from portable anchors. Each type of anchor has specific “rules” for how forces can be applied. The applied force must stay within the portable anchors construction features that counteract these forces. If, for instance, you pull the load outside of the triangle formed by the tripod base, it will fall over unless properly back tied.

**No matter the choice, artificial “high help” is only helpful when rigged soundly and properly.**

### Commercial Devices

There are many forms of commercially available portable anchors. NFPA 1983 does address portable anchors and provides for the certification of a Light-use and General-use portable anchor. However, not all commercial devices can meet these stringent requirements. Some forms of commercial portable anchors include tripods, bipods and quad pods. Many manufactures provide equipment that can meet many needs of the rescue team in regards to portable anchor application. It is always best practice to read and comply with the manufactures suggestions when constructing and applying any form of portable anchor. Load limits will vary with the configuration and extension of the device. Some commercial tripods can be converted into mono-pods, quad-pods or multi-pods. Each configuration has its own

set of “rules” on how forces can, and can not, be applied. It is important to understand and prepare for these various forces. The use of back-ties may be required to secure the legs or head of the device and counteract applied forces. Most devices can be extended to provide a higher attachment. Keep in mind that the rating of the device may vary with extension. Usually, the higher the device is extended, the lower the rated capacity. Generally, these devices should be setup on a level surface. However, it is permitted to offset the tripod legs to maintain plumb. The rating will be based on the longest leg.

#### Setup of a Commercial Tripod

- Follow manufacturer’s guidelines for assembly and operation.
- General guidelines:
  - Assemble away from hole or edge. Attach MA or rope system and then extend. Carry to hole and perform final adjustments.
  - Secure the legs with chains/ rope or webbing.
  - Some commercial devices provide attachment points to secure the legs to limit movement and counteract forces.

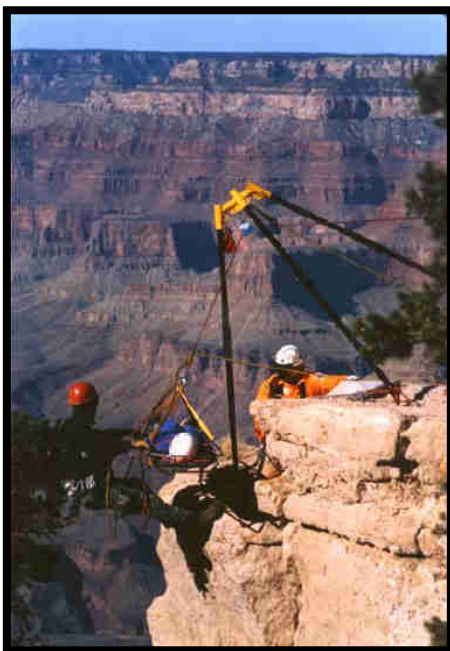

Tripods are diverse in design and use. Some tripods are designed for spanning a distance above a hole and some are designed for a variety of different height advantage applications. Round legs, square legs, height adjustments and winch capabilities are just a few of the options available when selecting a commercial tripod.

## Alternative uses for Fire Service Ladders

Many forms of portable anchors are available on most fire service apparatus. An improvised high directional or portable anchor can be safely constructed with some training, a little ingenuity and equipment. There are many forms of materials that can be safely used to construct bipods, tripods and mono-poles as high help. This class will focus on the dying science of using fire service ground ladders as an alternative for constructing and operating a portable anchor.

### Aerial Apparatus

The use of an aerial device as a high directional has become common practice for many departments throughout the country. However, aerials were not designed to perform like a crane, where the load is suspended below the boom and lifted up and down or swung to the left or right. To treat an aerial device in this manner can place undue stress on the boom and is potentially hazardous to the aerial device and the crews operating under and around it. It is best to setup the aerial boom above the point of departure, lock the apparatus controls and affix a high directional pulley to the ladder frame to facilitate its use in rope rescue. \

When using an aerial, or any other high directional, the team must understand that the forces applied to the directional anchor can exceed the weight of the load. Directional anchors can see up to 2 times the load on the rope system. Therefore, the aerials load rating must be known and measures taken ensure the forces applied to the aerial are within parameters. An aerial tip load chart is usually posted at the turntable controls and should be consulted before proceeding with any operation involving the use of an aerial as a high directional. Make sure the tip can support at least twice the anticipated load before using an aerial as a high directional anchor.

Some general guidelines should be followed when rigging and using aerials for rope rescue operations:

- Limit load size. Most aerials can not support the forces generated by a directional pulley when a patient and attendant is suspended below. Use taglines to clear obstructions.
- Keep forces inline with the center of the boom/ aerial and NEVER side load the aerial. Prevent loads from swinging outside plumb of the high directional. Absolute control of the loads position beneath the aerial is critical. Tagline attendants should not move the litter into a position that side loads the aerial.
- NEVER use the aerial to move the patient/ load.
- The belay should NOT be run through the high directional. The aerial probably will not have enough strength to sustain a shock load should a mainline failure occur. Consider not using a belay if the belay poses a greater hazard to the operation.

#### **WHAT DO AERIAL MANUFACTURERS SAY?**

Rob Haldeman from American LaFrance released a statement about using the company's LTI family of aerials for a HDAP in a high-angle rescue system. "We know that people are using the aerials in this way; we want to educate the industry about the concerns and hazards involved in using our aerials and platforms for high-angle rescue operations," Haldeman says.

*First, a determination must be made as to the unit's tip capacity. A load chart has been supplied and is mounted at each aerial control station. The load chart will identify the maximum tip load of the ladder or platform. Because most situations that require these techniques occur in remote areas, it is assumed that the ladder will be a full or near-full extension. In this case, no additional tip capacity can be figured.*

The manual supplied with your unit specifically warns that the ladder/platform is not to be used as a crane (lifting personnel and objects). These units were not designed for that type of loading.

In an emergency situation or a training exercise, you can use your aerial for a low- or high-angle rescue without risk to the ladder, if you follow these guidelines:

1. The weight of the equipment and personnel at the tip or suspended from it must not exceed the tip-load rating. See the load chart at the turntable console for this figure;
2. Use only approved procedures and techniques consistent with high-angle rescue;
3. Only personnel previously trained in high-angle rescue techniques should be involved in the procedure;
4. The attachment point for aerial ladder apparatus must be equally distributed from each side of the ladder fly section and from at least two rungs; preferably two points on each side of the ladder tip around both rung and rung rail. Platform units are optionally equipped with detachable or swing-out arms for tie-off of rigging for high angle operations. NOTE: Individual or combined loading of arms must be deducted from platform payload rating; and
5. A tether line should be attached to the stretcher or other personnel/loading to minimize swaying. NOTE: It is very important that the stretcher be kept as still as possible, not only for the passenger's safety but to avoid putting unusual stresses on the ladder. Even if the tip load rating is not exceeded, a swinging object of any type produces additional loading. The ladder was not designed for this type of loading and extreme care must be taken throughout the procedure.

Provided by Tom Pendley, FireRescue Magazine, August 2002

### Ladder Gin – One person load

A ladder gin is an upright ladder that is supported at the top by 2 guidelines to keep it in a near vertical position and equipped with a rope or pulley system for lowering or hoisting a load. It is designed to lift or lower loads vertically and requires that the load remain directly below the directional pulley and inline with the ladder. It is very versatile and can be set up in various areas using many forms of footing techniques such as against vehicles, curbs, etc. The Gin can be built with straight or extension ladders. When using extension ladders ensure the fly section is lashed to the bed section for added safety. This system is limited to the load rating of the ladders. As a rule of thumb, anchor systems should be at a 45 degree angle from the middle of the ladder and at a distance of three times the length of the ladder being supported.

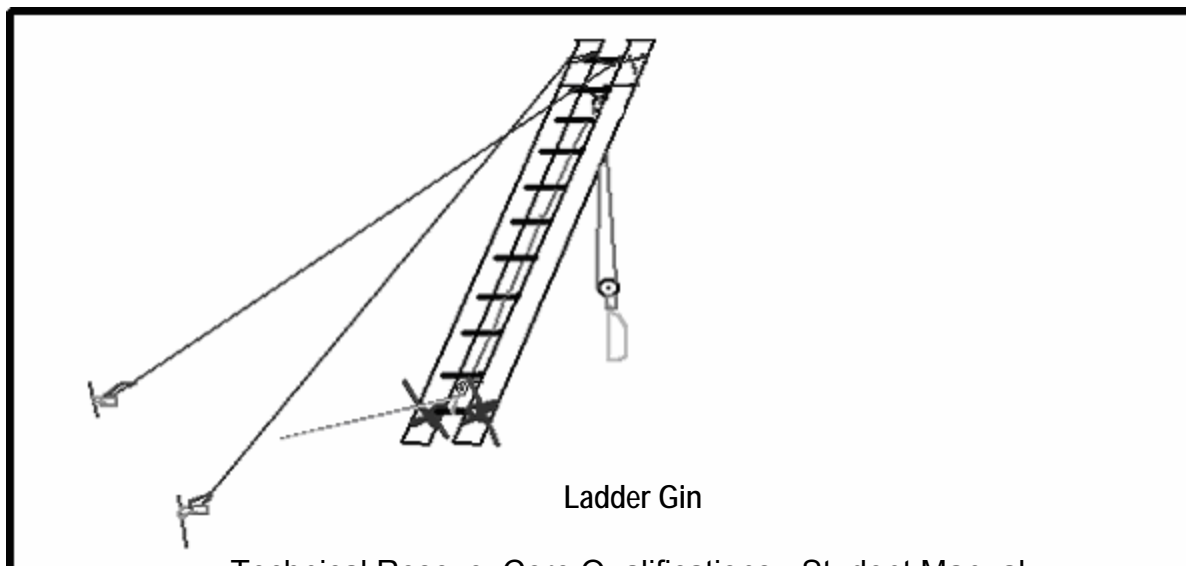

### To Construct the Ladder Gin:

- Lay ladder on the ground, extend to the desired height and lash the fly to the bed section.
- The two guidelines should be secured to the tip of the ladder with clove hitches to legs opposite the guideline anchors. You can use one rope to construct the two guidelines. It must be long enough to reach the anchor points. Leave a dead leg between the clove hitches long enough to be used to secure the high directional pulley.
- You will need two ropes for guidelines if a single rope is not long enough to do this. Secure each end of the single ropes to the beams, opposite their anchors, with clove hitches and a safety. Make a bridle for the directional attachment using webbing by encircling the ladder with a pretied loop of approximately 15 feet of webbing. Pull one side of the webbing through the space between the top two ladder rungs to form a basket hitch and make the necessary attachments.
- Attach the mechanical advantage system.
- Locate your guideline anchors at 45° angles to the ladder. The distance should be at least 3 times the height of the directional attachment. You can drive pickets if necessary.
- The guidelines should be secured to the anchors so the lengths can be adjusted easily. The guidelines can also be used to assist in lifting the ladder
- Several persons should lift the top of the ladder and “walk” it up by hand until the ladder is slightly off vertical. The base of each leg should be footed when lifting.
- Tension the guidelines until the ladder is slightly off-center, and then secure using prusiks or a trucker’s hitch.
- Drive pickets next to the beams of the ladder and secure them to the beams by lashing with webbing. This will prevent beams from moving.
- If necessary, attach a bottom directional pulley using a webbing bridle. The bottom directional should be positioned to limit friction in the system.
- An improvised method of lowering can be accomplished by wrapping the mainline around 2 or three ladder rungs.



## Ladder A-Frame – Load limited to rating of ladder(s)

A Ladder A-Frame is made by lashing two ladders together with webbing/rope and utilizes a directional pulley or mechanical advantage system suspended from the intersection. The A-Frame is most stable with four guidelines, but in certain circumstances, two can be used. It can be used as a vertical height advantage over a hole or as a high directional at or near an edge. The applied force must remain within the beams of the ladder for maximum strength. The A-Frame can also be built using round poles, timbers, steel bars, etc. The strength of the A-Frame will depend on the materials used in its construction and the intended purpose of the A-Frame.

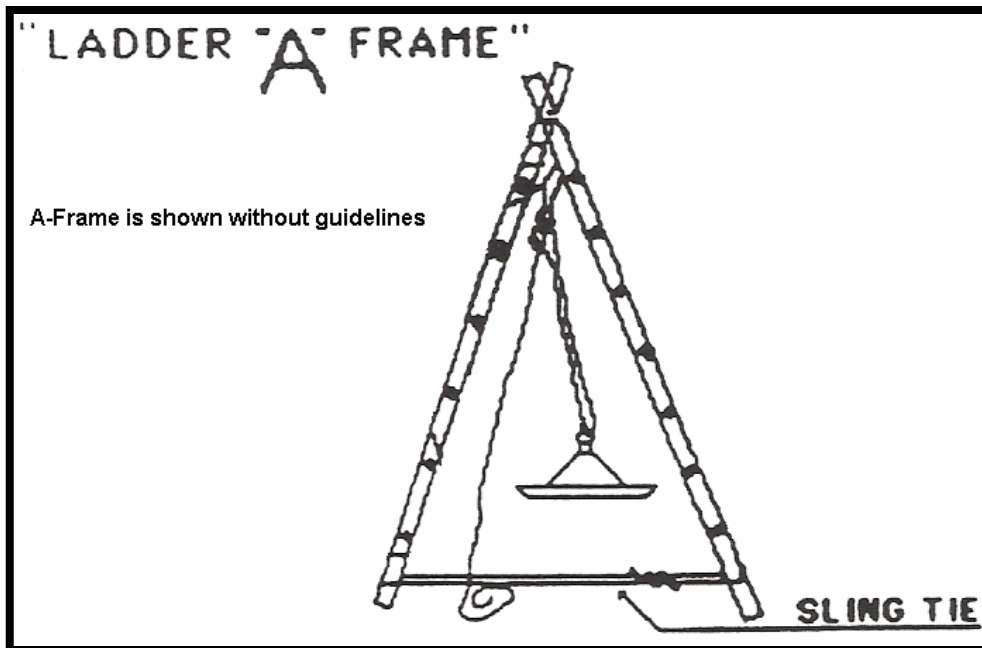

To Construct the Ladder A-Frame:

- Lay the ladders on their side, tips mated together and base spread apart approximately  $\frac{2}{3}$  the length of the ladder.
- Lash the tips together with webbing.
- At least 2 ropes will be needed for a 4 guideline system. Find the center of each rope and clove hitch onto the crossed beams of the ladders at the top.
- Guidelines should "oppose" each other. Resulting in the beams being pulled together.
- Attach the high directional/ MA system to a bridle at the top of the A-frame. Bridle should be secured to or around the beams of the ladder. A webbing bridle can be used to accomplish this.
- Anchors should be opposing and diagonal to the A-frame, at 45° angles. Anchors should be positioned at least a distance of 3 times the height of the directional attachment on the A-Frame.
- Attachment of the guidelines will follow same procedure as a Ladder Gin.
- Make final adjustments then use webbing to tie beams together at the base to limit movement.

## Other uses for fire service ladders

Fire service ladders can be used to provide many other forms of high help where commercial portable anchors do not exist or are ineffective. The application of FIRE SERVICE RATED ladders as high help is considered safe for use with single person loads in rope rescue operations. Loads applied to the ladders will need to be placed equally onto the ladders beams for maximum strength.

Exterior leaning ladders can be used to provide a high help above a window, or opening, to facilitate the removal of a victim from an upper floor that is accessible with a ground ladder. The ladder is placed above the window or point of departure and a directional pulley is affixed via a webbing bridle secured to the beams of the ladder. The belay should be anchored in a position at or above the point of departure. The ladder can be tied off or footed by at least 2 rescuers, depending on the intent and duration of the operation.

Interior leaning ladders can be used in situations where ground ladders will not reach the position above the point of departure. These ladders will be leaned against the header of the window or point of departure and a directional pulley is affixed via a webbing bridle secured to the beams of the ladder. The belay should be anchored in a position at or above the point of departure. The ladder can be tied off or footed by at least 2 rescuers, depending on the intent and duration of the operation. The angle of the ladder will dictate the kick-out force of the ladders base.

Cantilever ladders and Ladder Jibs are used in situations where the victim's location is further than ground ladders will reach and the use of an interior leaning ladder is not feasible. This incorporates the use of the ladder as a lever and requires that the ladder be AT LEAST 14 FEET IN LENGTH. The tip of the ladder is rigged with a webbing bridle and high directional pulley. The tip is then placed outside the window or over the roof edge. NO MORE THAN 1 RUNG FROM THE EDGE OF THE SUPPORTING STRUCTURE TO THE BRIDLE is extended over the edge. A 6:1 ratio is used for the weight at the base of the ladder compared to the load at the tip. *(if the load is 300# - the ladder base is 12 feet from the edge [fulcrum] with the bridle 2 feet out past the edge = 6:1 IMA. You will need at least 300# at the base of the ladder to counterbalance the load.)*

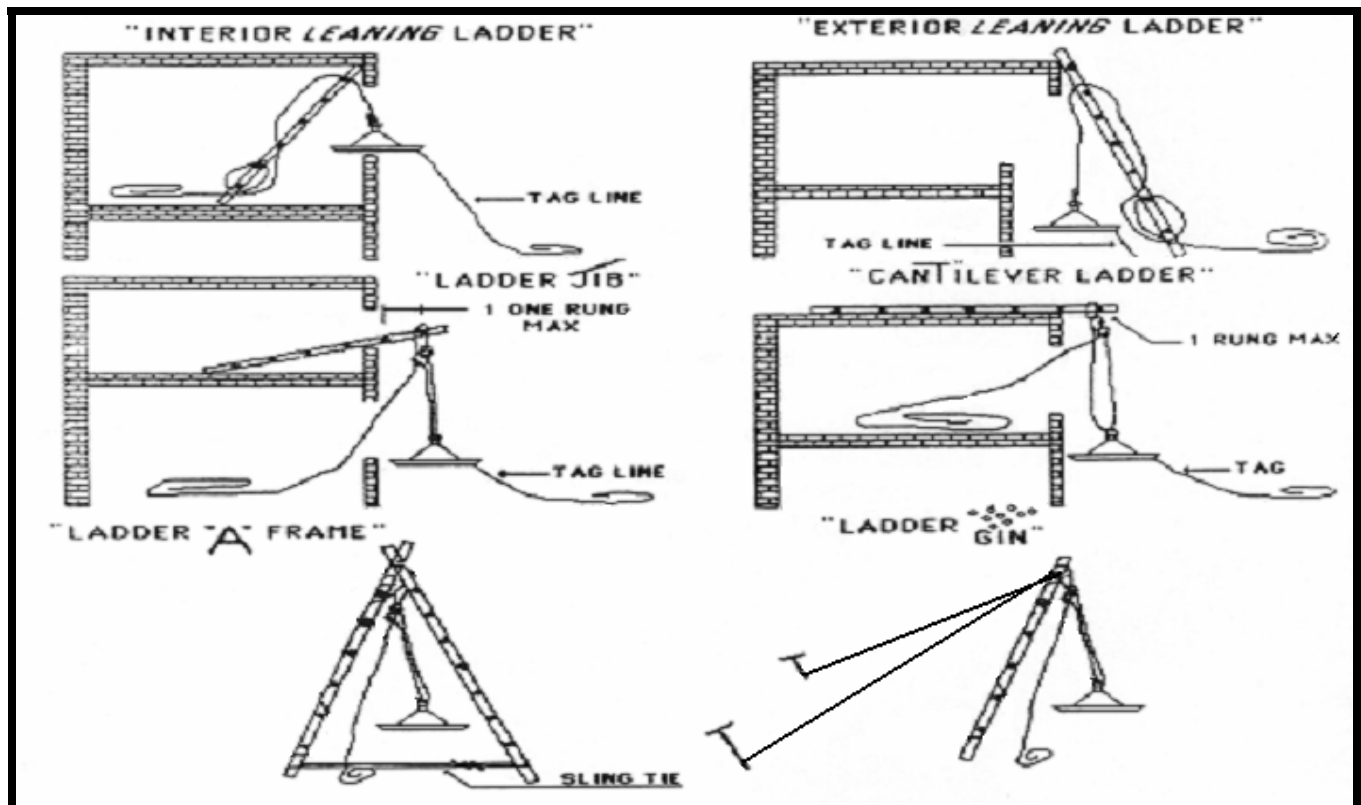

Some "alternative" uses for Fire Service ladders – Taken from Rescue Systems I Student Manual 1996

---

## Appendix

---





**Cascade Toboggan Model 200 Advance Series Rescue Litter  
Destructive Testing Results  
June 27, 2000**

# Cascade Toboggan Product Testing

Conducted at Rigging for Rescue in Invermere, BC Canada  
June 27, 2000

Intensive testing was conducted on the Cascade Toboggan Model 200 Advance Series Rescue Litter on June 27, 2000 at Rigging for Rescue in Invermere, BC Canada. The primary purpose of the testing was to determine the strengths and weaknesses of the Cascade Toboggan Model 200 Advance Rescue Litter and ancillary products. All testing was conducted by and under the supervision of Kirk and Katie Mauthner, the principals of Rigging for Rescue (RfR).

Detailed below are the test results. All tests with the exception of the One Meter Drop Test were conducted to a point of product failure. The results of these tests are provided for informational purposes only. Because the dangerous and varied nature which these products may be used for, Cascade Toboggan makes no claims regarding the products breaking strength, useful load, safety factors or intended use.

## **TEST ONE** – CTM200 Distributed Load Over Litter Bed in a Horizontal Orientation.

In this test the CTM200 was placed in a Slow Pull Device (SPD) whereby the ram of the SPD applied force directly to the bed of the litter at the point representing the litter's center of gravity under a specially made static harness constructed of heavy gauge chain and attached to the litter with steel carabiners. The distance from the top of the litter harness to the litter in the front was 74.5 inches; 77.5 inches in the rear.



A rigid backboard was manufactured to place in the bottom of the litter to distribute the load of the SPD across the length of the litter. The footprint of the backboard was 60 inches by 11.25 inches. The distance from the center of the ram to the end of the litter was 47.25 inches and from the head of the litter to the ram was 34.75 inches.

## **Results and Observations**

Force was applied gradually over a period of 32 seconds. Approximately 15 seconds into the test the litter sustained a downward load of 39.84kN. At this point the carabiner attached to right forward railing sheared through the railing. Force then dropped to approximately 22kN before climbing back to approximately 30kN when the left front railing sheared through



the bracket closest to the carabiner. At this point, the litter, while badly damaged was still attached to the litter harness by three of four attachment points. After several more seconds it was determined the litter had sustained enough damage to render it inoperable. Absolutely no damage was done to the <sup>1</sup>Fastlock™ System and the remnants of the litter were disassembled at the completion of the test.

**TEST TWO** - CTM200 Non-Distributed Load Over Litter Bed in a Horizontal Orientation (smaller footprint, simulation of pinpoint load at center of gravity).

Test Two is identical in all respects to Test One with the exception that the footprint of where a load was applied was reduced to an 18 inch by 11.25 inch area directly over the center of gravity of the litter as it was attached to the static litter harness.

**Results and Observations**

Force was applied gradually over a period of 40 seconds. Approximately 11 seconds into the test the litters sustained a downward load of 10kN. The litter then flexed and at approximately 28 seconds into the test failed at a sustained force of 10.06kN. The central point of failure occurred where the litter railing connected the <sup>1</sup>FastLock™ Coupler. The litter itself remained in one piece, but was considered to be inoperable.



**TEST THREE** - CTM200 End to End Pull

This test was designed to simulate the impact of load placed on the CTM200 if placed in an end to end “Inline” pull. The CTM200 was placed in the SPD and rigged with a 3 point inline litter harness as specified by the Technical Rescue Riggers Guide published by Rick Lipke. The litter harness was constructed of 11mm static Kernmantle rope.



**Results and Observations**

Force was applied gradually over a period of 28 seconds. At approximately 15 seconds force built up to 16.55kN. The first point of failure occurred where the nose railing bracket connected to the shell of the litter. The litter maintained structural integrity at a sustained force in excess of 15 kN until both the left and



right railing brackets at the nose were pulled from the shell and one end of the litter railing sheared from the FastLock™ System. It was observed that the litter was still in one piece and could be considered functional although patient integrity could have been compromised. It was also observed that the railing of the litter was the cause of central failure due to buckling.

#### **TEST FOUR** – One Meter Drop

This test simulated a sudden, unexpected drop of the litter and the impact it could sustain from such a drop. The litter was rigged in a static litter bridle constructed of heavy gauge chain and attached to the litter with steel carabiners. The distance from the top of the litter harness to the litter in the front was 41 inches, 38 inches in the rear and 33.5 inches from the axis of the bridle to the railing of the litter at its center of gravity. The litter harness was then attached to three meters of 11mm static rope. The static rope was



folded and tied to contain one meter of slack that could be instantly loosed to simulate the drop. The CTM 200 as tested weighed 19 lbs and was loaded with a Rescue Randy weighing 173 pounds for a total weight of 197 pounds. The litter was hoisted up a drop tower for the test.

#### **Results and Observations**

The CTM200 bounced slightly (approximately 3 inches) upon impact at the bottom of the rope. Impact was measured at 6.52kN. There was a very slight flex at the midpoint of the litter on impact. There was no damage to any part of the litter or railing.

#### **TEST FIVE** – Slow pull of CTM200 Vertical Pull Brackets

This test was conducted to determine the failure strength of the CTM200 configured with Vertical Pull Brackets used in a vertical raise or lower configuration. The nose end of the litter was used and was bolted to the SPD. A static bridle was attached to the Vertical Pull Brackets and attached to the SPD at a distance of 39.25 inches from the load. The width between the Vertical Pull Brackets was 20 inches.



### **Results and Observations**

Force was applied over a period of 12 seconds. Peak force applied was 34.58kN at which time large sections of the litter shell cracked and allowed the Vertical Pull Brackets to move forward. As the Vertical Pull Brackets moved forward against the litter railing brackets, force was transferred to the litter railing ultimately causing it to buckle.



### **TEST SIX – CTM200 Litter Railing Bracket Pull Out**

Each CTM200 Rescue Litter contains 14 Railing Brackets. This test was conducted simply to determine the “pullout” strength of the CTM200 Railing Bracket from the litter shell. A panel of fiberglass of the same composition as the litter shell was mounted to the SPD. Force was then applied to the Railing Bracket until failure.

### **Results and Observations**

Force was applied and at 15.03 kN the litter Railing Bracket pulled out of the fiberglass panel.

## General Observations and Conclusions

In most cases the strength of the Cascade Toboggan Model 200 Advance Series Rescue Litter greatly surpassed the expectations of the manufacturer and satisfied the requirements of all testing specifications. The fiberglass shell proved to be extremely tough and able to withstand a great deal of punishment. The new Cascade Toboggan Fastlock™ System was never damaged in any of the tests and proved to be of superior strength.

Areas that were noted for improvement were the strength of the litter railing and the rivets used to assemble the product. Since these tests were conducted, many changes have been made to the CTM200. The galvanized mild steel railing has been replaced with 5/8 T304 stainless steel with a tensile strength of 92,100 psi. Steel hollow barrel style rivets have been replaced with solid aircraft grade aluminum pressed rivets with a shear strength of 28,000 psi and stainless steel rivets with a tensile strength of 1,300psi and shear strength of 1,150psi. The new pressed rivets also greatly improve the finish on the interior of the CTM200.

---

*The CTM200 is an excellent choice for all high incline, backcountry and general rescue operations. Cascade Toboggan will continue to improve upon its designs and test them thoroughly to ensure only the safest products of the highest quality are introduced for dedicated professionals to use.*

1. The CTM200 FastLock™ System is comprised of a laser cut stainless steel interlocking bedplate and two FastLock™ Couplers machined from 6061 T6 Series aluminum, hard anodized with Teflon on each rail of the CTM200.

For more information please contact Dana Jordan at Cascade Toboggan Rescue Equipment Company. Phone: (425) 888-6922 Fax: (425) 888-6945 or [Cascadetoboggan.com](http://Cascadetoboggan.com).

This document may be shared, but may not be used in any fashion that could be construed as detrimental to the publisher and in no way implies guarantees or warranties of product of any kind.

MARCH 2003 OHS

Will Your Safety Harness Kill You?

**Workers and emergency response personnel must be trained to recognize the risks of suspension trauma.**

*by Bill Weems and Phil Bishop*

I was surprisingly comfortable with my legs dangling relaxed beneath me, and my arms outstretched in a posture that must have resembled a crucifixion. I had no feeling of stress and mused as to why this was considered dangerous. I felt I could stay in this position for a long time. Three minutes later, maybe less, I wondered why I suddenly felt so hot. The next thing I knew, they were reviving me from unconsciousness. I had just experienced what could be deadly for your workers who use safety harnesses. Fortunately for me, my suspension trauma occurred in the safe environment of the research ward of University of Texas Medical Branch Hospital at Galveston, Texas, where I was the first subject in a NASA experiment studying orthostatic intolerance in astronauts. Your workers won't be so lucky.

### **Harness-Induced Death**

Wide ranges of situations require safety harnesses of various types. Workers requiring fall protection, workers entering many confined spaces, mountain climbers, deer hunters in elevated stands, and cave explorers all try to protect themselves through the use of safety harnesses, belts, and seats. What is little known however, is that these harnesses can also kill. Harnesses can become deadly whenever a worker is suspended for durations over five minutes in an upright posture, with the legs relaxed straight beneath the body. This can occur in many different situations in industry. A carpenter working alone is caught in mid-fall by his safety harness, only to die 15 minutes later from suspension trauma. An electrical worker is lowered into a shaft after testing for toxic gases. He is lowered on a cable and is positioned at the right level to repair a junction box. After five minutes he is unconscious--but his buddies tending the line don't realize it, and 15 minutes later a dead body is hauled out. The cause of this problem is called "suspension trauma." Fall protection researchers have recognized this phenomenon for decades. Despite this, data have not been collected on the extent of the problem; most users of fall

protection equipment, rescue personnel, and safety and health professionals remain unaware of the hazard.

### **Suspension Trauma**

Suspension trauma death is caused by orthostatic incompetence (also called orthostatic intolerance). Orthostatic incompetence can occur any time a person is required to stand quietly for prolonged periods and may be worsened by heat and dehydration. It is most commonly encountered in military parades where soldiers must stand at attention for prolonged periods. Supervisors can prevent it by training soldiers to keep their knees slightly bent so the leg muscles are engaged in maintaining posture.

What happens in orthostatic incompetence is that the legs are immobile with a worker in an upright posture. Gravity pulls blood into the lower legs, which have a very large storage capacity. Enough blood eventually accumulates so that return blood flow to the right chamber of the heart is reduced. The heart can only pump the blood available, so the heart's output begins to fall. The heart speeds up to maintain sufficient blood flow to the brain, but if the blood supply to the heart is restricted enough, beating faster is ineffective, and the body abruptly slows the heart.

In most instances this solves the problem by causing the worker to faint, which typically results in slumping to the ground where the legs, the heart, and the brain are on the same level. Blood is now returned to the heart and the worker typically recovers quickly. In a harness, however, the worker can't fall into a horizontal posture, so the reduced heart rate causes the brain's blood supply to fall below the critical level.

Orthostatic incompetence doesn't occur to us very often because it requires that the legs remain relaxed, straight, and below heart level. If the leg muscles are contracting in order to maintain balance and support the body, the muscles press against the leg veins. This compression, together with well-placed one-way valves, helps pump blood back to the heart. If the upper-legs are horizontal, as when we sit quietly, the vertical pumping distance is greatly reduced, so there are no problems.

In suspension trauma, several unfortunate things occur that aggravate the problem. First, the worker is suspended in an upright posture with legs dangling. Second, the safety harness straps exert pressure on leg veins, compressing them and reducing blood flow back to the heart. Third, the harness keeps the worker in an upright position, regardless of loss of consciousness, which is what kills workers.

## **Phases of Fall Protection**

There are four phases of fall protection: Before the fall, at fall arrest, suspension, and post-fall rescue. Each phase presents unique safety challenges. Suspension trauma can be influenced by all aspects of the fall, so they are all important. As with many aspects of safety, increasing the safety in one phase can compromise the safety of the others. Whatever training workers have received will determine how they respond to different phases. Here is a brief discussion of each aspect of fall protection.

### *Before the fall*

The key issue of fall protection before the fall is compliance. If a harness is too uncomfortable, too inconvenient, or interferes too much with task completion, workers may not use the equipment or may modify it (illegally) to make it more tolerable. A second major point is the length of the attachment lanyard, or, how far can a worker fall before his fall is arrested? The longer the fall, the greater the stress on the body will be when the fall is arrested. The shorter the lanyard, the more often it will have to be repositioned when workers are mobile. A moveable safe anchor is one solution, but this situation is only occasionally available.

### *Fall arrest*

The whole concept of fall protection is that workers who fall will be stopped by the tethering system. The longer the attachment lanyard, the greater the acceleration time during the fall and the greater the stress on the body at arrest. Unfortunately, the posture of the falling worker is unpredictable. Depending on the harness attachment point and the position of the worker's body at arrest, different harness attachments offer different advantages. An attachment near the shoulders means that any drag from the lanyard will serve to position the worker's body in an upright position so the forces are distributed from head to foot. The head is somewhat protected if the legs and body precede it in the fall, but this offers some disadvantages after the fall arrest is completed.

### *Suspension*

Many safety professionals naturally assume that, once a fall has been arrested, the fall protection system has successfully completed its job. Unfortunately, this is *not* the case. A worker suspended in an upright position with the legs dangling in a harness of any type is subject to suspension trauma.

Fall victims can slow the onset of suspension trauma by pushing down vigorously with the legs, by positioning their body in a horizontal or slight leg-high position, or by standing up. Harness design and fall injuries may prevent these actions, however.

### *Rescue*

Rescue must come rapidly to minimize the dangers of suspension trauma. The circumstances together with the lanyard attachment point will determine the possibilities of self-rescue. In situations where self-rescue is not likely to be possible, workers must be supervised at all times. Regardless of whether a worker can self-rescue or must rely upon others, time is of the essence because a worker may lose consciousness in only a few minutes. If a worker is suspended long enough to lose consciousness, rescue personnel must be careful in handling such a person or the rescued worker may die anyway. This post-rescue death is apparently caused by the heart's inability to tolerate the abrupt increase in blood flow to the right heart after removal from the harness. Current recommended procedures are to take from 30 to 40 minutes to move the victim from kneeling to a sitting to a supine position.

### **Interference Among Phases**

An arrest harness attachment on the front of the body facilitates self-rescue after a fall. However, a front attachment means the arresting lanyard may be in the way for many work tasks. An attachment point near the center of gravity (CG) makes post-fall body positioning much easier and increases the likelihood that a fallen worker will not be suspended in an upright vertical position.

Yet a front near-CG attachment point can greatly increase the bending stress on the spine at the instant of arrest, raising the possibility that the arrest itself results in serious injury. The most protective harnesses for suspension can be the least comfortable.

### **Recommendations**

Safety harnesses save many lives and injuries. However, continual vigilance is needed to train and supervise workers to ensure harnesses are used safely. All phases of fall protection need to be examined for each particular application. Workers and emergency response personnel must be trained to recognize the risks of suspension trauma.

*Before the potential fall:*

- 1) Workers should never be permitted to work alone in a harness.
- 2) Rope/cable tenders must make *certain* the harness user is conscious at all times.
- 3) Time in suspension should be limited to under five minutes. Longer suspensions must have foothold straps or means for putting weight on the legs.
- 4) Harnesses should be selected for specific applications and must consider: compliance (convenience), potential arrest injury, and suspension trauma.
- 5) Tie-off lanyards should be anchored as high and tight as work permits.

*After a fall:*

- 1) Workers should be trained to try to move their legs in the harness and try to push against any footholds.
- 2) Workers hanging in a harness should be trained to try to get their legs as high as possible and their heads as close to horizontal as possible (this is nearly impossible with many commercial harnesses in use today).
- 3) If the worker is suspended upright, emergency measures must be taken to remove the worker from suspension or move the fallen worker into a horizontal posture, or at least to a sitting position.
- 4) All personnel should be trained that suspension in an upright condition for longer than five minutes can be fatal.

*For harness rescues:*

- 1) The victim should not be suspended in a vertical (upright) posture with the legs dangling straight. Victims should be kept as nearly horizontal as possible, or at least in a sitting position.
- 2) Rescuers should be trained that victims who are suspended vertically before rescue are in a potentially fatal situation.
- 3) Rescuers must be aware that post-rescue death may occur if victims are moved to a horizontal position too rapidly.

*Recommendations on harnesses:*

- 1) It may be advantageous in some circumstances to locate the lanyard or tie-off attachment of the harness as near to the body's center of gravity as possible to reduce the whiplash and other trauma when a fall is arrested. This also facilitates moving legs upward and head downward while suspended.

- 2) Front (stomach or chest) rather than rear (back) harness lanyard attachment points will aid uninjured workers in self-rescue. This is crucial if workers are not closely supervised.
- 3) Any time a worker must spend time hanging in a harness, a harness with a seat rather than straps alone should be used to help position the upper legs horizontally.
- 4) A gradual arrest device should be employed to lessen deceleration injuries.
- 5) Workers should get supervised (because this is dangerous) experience at hanging in the harness they will be using. [OHS endbug]

*Bill Weems (bweems@ccs.ua.edu) and Phil Bishop are at the University of Alabama, in Tuscaloosa, Ala. Dr. Weems is an industrial hygienist. He directs Safe State, the OSHA consultation agency for small business in Alabama. Dr. Bishop is an ergonomist. He teaches and conducts research in the physiology of human performance.*

### **Reference**

Seddon, Paul. *Harness Suspension: review and evaluation of existing information*. Health and Safety Executive. Research Report 451/2002. 104 pp.

Pull quotes:

All personnel should be trained that suspension in an upright condition for longer than five minutes can be fatal.

Depending on the harness attachment point and the position of the worker's body at arrest, different harness attachments offer different advantages.

Fall victims can slow the onset of suspension trauma by pushing down vigorously with the legs, by positioning their body in a horizontal or slight leg-high position, or by standing up.



**FireRescue Magazine**  
**August 2002**

Vol. 20 Issue 8

## Sky-High Anchors

By Tom Pendley

**Tech rescue reaches new heights with cranes & aerials**



**PHOTOS, ILLUSTRATIONS TOM PENDLEY**

The urban setting harbors a lot of hazardous and challenging high-angle rescue potential. Large construction sites, for example, can present obstacles such as excavations with complex concrete forms and rebar reinforcement structure, elevated work areas on steel structures and freeway bridge projects. Other urban sites with difficult access may include water towers, bridges and holding tanks.

Rescuers can usually reach a victim in these locations by climbing, but moving the patient to a safe area can take a long time and expose rescuers to significant hazards. An onsite crane or fire department aerial apparatus can prove valuable by providing rescuers a high directional anchor point (HDAP) for the technical rescue system.

An HDAP can simplify and expedite movement of the patient packaging device, but many hazards and concerns exist that rescuers must address in order to perform this type of rescue safely.

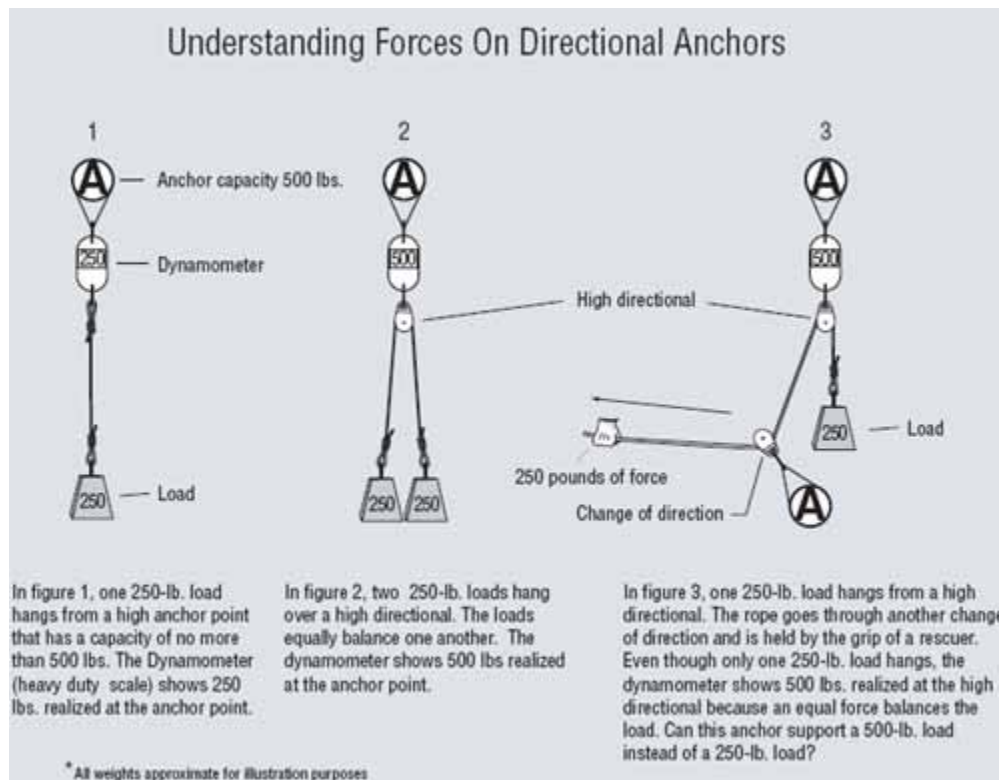



All aerials and cranes feature a capacity chart mounted at the control station. The equipment operator should do a dry run with the aerial or crane to ensure it has sufficient tip capacity to do the job. Remember, the force exerted on the high directional equals double the load.

## DIRECTIONAL ANCHORS

When using rope retrieval systems, we resist the force of gravity. *Plumb* refers to a resistance angle perpendicular to, or 90 degrees from, level ground. When an object hangs freely from a string or a rope, it will always seek the natural plumb line directly below the point to which it is attached.

*Fall line* describes the point where a rope system runs over an edge and down into a vertical drop. The rope system changes direction as it goes over the edge and into the fall line. The fall line is essentially a plumb line except that it is influenced by obstacles, such as slope angle and tag lines. On the mountain, the edge is one of the most difficult parts of a high-angle operation. We like to get the rope up off the ground at the edge with some type of high directional (HD). *Example:* an A-frame placed at the edge or an overhead structural beam at the edge. A high directional at or near the edge makes moving the litter and attendant over the edge much easier than if the main rope simply runs over a roller on the ground at the edge.

If the rescue package at the rope's end moves out of the fall line due to attendant movement or some other force, gravity will naturally want to return it to the fall line with a pendulum swing. In some cases, it's not ideal to locate the natural fall line below the main anchor. If you place a directional anchor for the main rope out of the fall line, you can create a directed fall line and prevent the rescue package from swinging into the old fall line.

*A critical point:* A change of direction can place more force on the directional anchor than the actual weight of the load attached to the end of the rope. A maximum force of 200 percent of the load is possible if the rope angle entering and leaving the directional pulley is zero degrees. As this angle increases, the force on the directional anchor diminishes. (For example, at 90 degrees, the force on the directional anchor drops to approximately 140 percent of the load.)



Unless your aerial has a built in anchor point near the tip (some Metz aerials do), you need to create an anchor point at the tip (never tie off to two sections at once). Lay the 20' webbing over both rails and then bring the ends up through the adjacent rails. Tie the webbing with a standard water bend.

## AERIALS AS HIGH DIRECTIONALS

Virtually every jurisdiction with multi-story structures has an aerial apparatus. Using an aerial apparatus or a crane to reach a difficult-to-access patient can greatly reduce the time necessary to affect a rescue. However, keep in mind most aerial apparatus were not designed to perform like a crane — i.e., suspend a load from some point on the aerial, then hoist it up or down and/or swing it left or right with the hydraulic or winch system.

Overloading an aerial by lifting loads with hydraulic systems could result in a catastrophic boom collapse. Also, OSHA regulations prohibit hoisting or swinging people with a crane unless they ride inside a certified personnel platform (a man basket).

OSHA 29 CFR 1910.180 (h) (3) (v) standard for crawler, locomotive and truck cranes states, "No hoisting, lowering, swinging, or traveling shall be done while anyone is on the load or hook." The standard speaks to the hook and boom movement, not a manually operated rope system attached to it.

There is a difference between using an aerial as a crane and using it as an HDAP. Using an aerial as an HDAP means the anchor is safely attached to the outer fly section or the bottom of the platform. The main line is then placed in a pulley and connected to the HDAP, the aerial is moved into position above the desired fall line and the control platform is locked out and tagged with a do-not-operate label so no one will move it.

You can use cranes similarly. Attach the HDAP to the hook with a rated anchor strap or webbing. Place the main line in a pulley and attach it to the HDAP. Then, position the hook above the desired fall line, lock the control panel out and secure any mechanical winch locks.

Once you decide to use an aerial for a HDAP, give some thought to apparatus placement. Closer placement to the load will allow steeper elevation and less extension of the aerial, resulting in greater load capacity. The angle of the apparatus in relation to the location of the

load is also important. Try to park so the aerial will line up with one of the outriggers.. This will help with rigging a change of direction in the system in line with the aerial to prevent side loading and to allow for a working area for raising and lowering operations.



Pull the two upper sections down between the second and third rungs and clip both loops with a steel carabiner. Clip both lower loops with a carabiner, bring the carabiners together and connect them to a rigging plate. Check for sharp edges, and then attach the high directional pulley to the plate.

three rungs from the tip. Next, bring the ends up through the adjacent rungs and tie a water bend. Pull the top two loops down, collect the bottom two loops and fasten each set of loops with a steel carabiner. Connect a rigging plate to the two carabiners and then attach the directional pulley with the main line in it to the rigging plate.

Once you spot the rig and deploy the outriggers, take the aerial up and position it above the load. Be sure to leave about 10 feet of clearance above any obstruction. Adequate clearance is important so the rescue package has room to move between the obstruction and the HDAP. If there is not enough clearance, rescuers may feel pressured to raise the aerial up, which is prohibited and dangerous while a person is suspended from it.

#### **AERIAL- OR CRANE-TIP CAPACITY**

Once the aerial is in position, the apparatus operator must determine the unit's tip capacity. Using the capacity chart as a reference, determine if the unit can support twice the weight of the intended load. If the unit is within its rated capacity for the operation, the team can proceed with rigging.

#### **RIGGING THE AERIAL**

Bring the aerial in and down to the level position or lower (if possible) in order to rig the HDAP. Lay the webbing — a 20' piece of 1" tubular webbing works well — over the aerial's main rails between two rungs about two or



This midmount aerial does not offer designated anchor points near the turntable. The outrigger makes an ideal directional anchor, but it's critical that the working line aligns with the center of the aerial to prevent side load. Here, a second directional (the yellow rope) redirects the working line on center with the aerial.



Anchor the belay from a point above the load if possible. In this operation, a roof vent structure was used to anchor the belay for the single-person load

or patient packaging device is not already there) so they can quickly set the anchor (if possible) and remain ready to belay once the patient is packaged.

Place the main line into the high directional pulley and tie the end of the main line to the litter bridle yoke with a standard tie-in method — a doubled long tail bowline, for example.

### THE BELAY

Using a second rope to belay the load is considered standard, but it can be difficult to belay as usual using a standard belay technique. Initially you might consider rigging a second pulley at the high directional and belaying from the base of the ladder or crane. In most cases, however, the aerial will have barely enough capacity to support the load, and it couldn't withstand any type of shock load if the main line or anchor failed for some reason.

Therefore, you must belay from a separate anchor point in a good position. Make every effort to establish a sound belay for the patient, but *do not* belay through the high directional point. Unfortunately, this can present one of your operation's biggest challenges. Some may consider it technical-rescue blasphemy to recommend not using a belay in certain situations. However, if the belay itself poses a greater hazard than having no belay, go without a belay or an attendant and minimize time spent in the vertical.

*Tip:* To speed things up on belay rigging, pre-rig the belay line into the litter yoke with the main line. Place the rope bag with necessary hardware into the basket and send it up to the rescuers at the accident site (if the litter



A 5:1 MA system is used to both raise and lower the load. Lowering with an MA system is easy, and it eliminates the need to switch over from a raise to a lower. Here, the system is ganged onto the working line with a ratchet man at the main anchor. To lower, the ratchet man holds back or minds the pulley as the haulers lower the load.

## **POSITION THE HDAP**

Once you've completed rigging the aerial, move the aerial or hook into position. Let rope flow freely through the system until the HDAP sits above the load. Then, the haul team can place a ratchet on the main line and prepare to set up an MA system. Do not set up the MA system until the HDAP is in position.

## **TO ATTEND OR NOT TO ATTEND**

Placing a rescuer on the litter as a litter attendant effectively doubles your load, which may climb to nearly 1,000 lbs. at the HDAP. Many aerials simply can't support that large a load. Two tag lines held by rescuers near the base of the aerial typically offer the best way to guide the single-person load and control sway. In the urban setting, most situations do not require an attendant. Good technique should accomplish patient evacuation in just a few minutes once you lift them into the air.

## **LOW DIRECTIONAL ANCHORS (CHANGE OF DIRECTION)**

Side pull on an aerial or crane can cause catastrophic boom failure. Apply good technique to avoid this. To keep the system in line with the aerial/boom and create a good

control area for the system, place a directional anchor at ground level somewhere on the apparatus. The foot of an outrigger makes a solid directional anchor, as do designated anchor points at the rear of the rig. This is when careful thought during rig placement comes into play.

## **THE SYSTEM**

Even though most situations only require lowering, experience has proven you will usually need to raise at least a few feet sometime during the operation. It may be more efficient to hoist the empty basket to the patient site without any mechanical advantage. Once the rescuers with the patient start packaging build a 3:1 MA system (either integral to the main line or ganged onto it) and use the MA to both raise and lower.

To lower with an MA system, tell the haul team to prepare to lower and give the command, "Man the ratchet." The rescuer assigned to the

ratchet (the ratchet is the rope grab device attached to the working line and the main anchor in order to check the forward progress of the load) should hold it back from locking once the tension is off and report, "Ratchet manned, ready to lower." Then you can command the haul team to lower slowly. The tag line teams should work together to keep the load stable and clear of obstacles.

When the MA system draws near full extension, give the commands, "Stop," "Set the ratchet" and "Reset." Move the MA haul grab/prusik back to the anchor by hand to reset the system for lower. Once reset, repeat the lower commands and continue lowering.



This 150-ton crawler crane features a 130' lattice boom that allows it to reach a large area. Tracks allow the crane to move quickly around the construction site.

### **CRANE-HOOK SETUP**

If you plan to use a crane hook for your HDAP, there are some special considerations. If the hook or load block is more than a few feet from the top of the boom (cable reeled out), movement of the fall line will result when the main line is tensioned. This can present a big problem in some situations. *The solution:* Either keep the hook in the fully up position, or place the hook where you want it and rig an opposition line (usually a 3:1 MA) exactly opposite the direction of pull on the main line. Thus, you can position the HDAP into the desired fall line by adjusting tension on the opposition line. *Caution:* When using opposition systems on a crane hook, ensure side force does not occur on the hook gate. Attaching all systems to a rigging plate hanging from the hook usually prevents this

problem. A backup strap can be rigged between the anchor plate and the cable or hook block in case you are concerned that the primary anchor could slip off the hook.

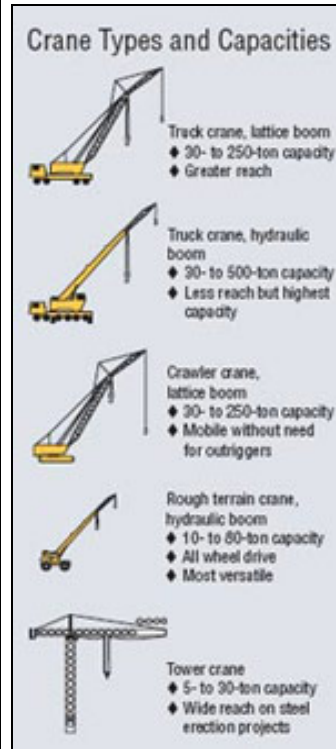
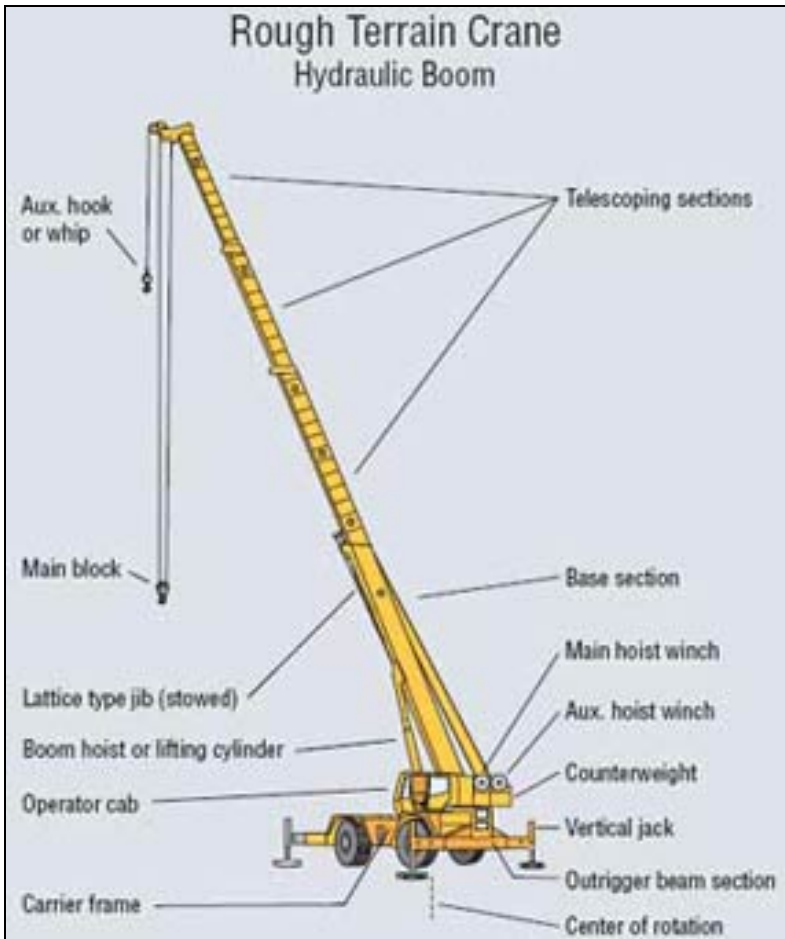

This rescue team used a 60-ton, rough-terrain crane to provide a HDAP over the center of an abandoned mine shaft. In this case, the belay also changed direction at the hook because the crane capacity was more than 20 times the hook load.



Outriggers tend to give truck cranes higher capacity than crawlers. This rig features a 230-ton capacity and a 220' lattice boom.

## **CONCLUSION**

Using available aerials and cranes for HDAPs can greatly speed up the technical evacuation of an injured person from a challenging location in the urban setting. This remains another tool for the trained rescue team that practices to maintain proficiency. Use it wisely and appropriately and within the limits of the team and the apparatus.



This hook block belongs to a 150-ton crane. Weighing in at 650 lbs., it offers a substantial anchor point.



The crane operator must be able to see the boom-mounted inclinometer to ensure they stay within the crane's capacity.

*Rescue Editor Tom Pendley is a captain/paramedic with the Peoria (Ariz.) Fire Department and a member of its technical rescue team. Pendley teaches technical rescue for the Phoenix Fire Department and is currently a technical rescue instructor for the Arizona State Fire Marshal's office. He also is the author of *The Essential Technical Rescue Field Operations Guide*. He can be reached at 623-533-1234, [desertrescue@aol.com](mailto:desertrescue@aol.com).*

## GLOSSARY

- **Angle indicator** — A visual indicator of the boom's inclination angle. It's mounted on the boom in view of the operator.
- **Auxiliary hoist** — A supplemental hoisting unit of lighter capacity and usually higher speed than the main hoist.
- **Boom** — The steel arm of the crane that holds the load. Comes in either a solid telescoping style or a lattice steel style.
- **Counterweight** — Large weights mounted at the back of the crane. Also refers to the hook or shackle and weight suspended from the auxiliary hoist rope.
- **Jib** — The lattice structure attached to the end of the boom. The jib gives the crane more reach but lowers its capacity.
- **Lift** — The maximum height the hook rises above the floor.
- **Load block** — The assembly of hook or shackle, swivel, bearing, sheaves, pins, and frame suspended by the hoist.
- **Load chart** — The chart for each individual crane that shows maximum capacity at different boom angles and extensions.
- **Main hoist** — The hoist mechanism for lifting the maximum-rated load.
- **Outriggers** — Comprised of the beam (the leg of the outrigger) and the pad (the foot).
- **Rope** — Wire rope in the crane world.
- **Whip** — The auxiliary hoist.

### WHAT DO LADDER MANUFACTURERS SAY?

Rob Haldeman from American LaFrance released a statement about using the company's LTI family of aerials for a HDAP in a high-angle rescue system. "We know that people are using the aerials in this way; we want to educate the industry about the concerns and hazards involved in using our aerials and platforms for high-angle rescue operations," Haldeman says.

*First, a determination must be made as to the unit's tip capacity. A load chart has been supplied and is mounted at each aerial control station. The load chart will identify the maximum tip load of the ladder or platform. Because most situations that require these techniques occur in remote areas, it is assumed that the ladder will be a full or near-full extension. In this case, no additional tip capacity can be*

*figured.*

*The manual supplied with your unit specifically warns that the ladder/platform is not to be used as a crane (lifting personnel and objects). These units were not designed for that type of loading.*

*In an emergency situation or a training exercise, you can use your aerial for a low- or high-angle rescue without risk to the ladder, if you follow these guidelines:*

- 1. The weight of the equipment and personnel at the tip or suspended from it must not exceed the tip-load rating. See the load chart at the turntable console for this figure;*
- 2. Use only approved procedures and techniques consistent with high-angle rescue;*
- 3. Only personnel previously trained in high-angle rescue techniques should be involved in the procedure;*
- 4. The attachment point for aerial ladder apparatus must be equally distributed from each side of the ladder fly section and from at least two rungs; preferably two points on each side of the ladder tip around both rung and rung rail. Platform units are optionally equipped with detachable or swing-out arms for tie-off of rigging for high angle operations. NOTE: Individual or combined loading of arms must be deducted from platform payload rating; and*
- 5. A tether line should be attached to the stretcher or other personnel/loading to minimize swaying. NOTE: It is very important that the stretcher be kept as still as possible, not only for the passenger's safety but to avoid putting unusual stresses on the ladder. Even if the tip load rating is not exceeded, a swinging object of any type produces additional loading. The ladder was not designed for this type of loading and extreme care must be taken throughout the procedure.*